

System components and accessories

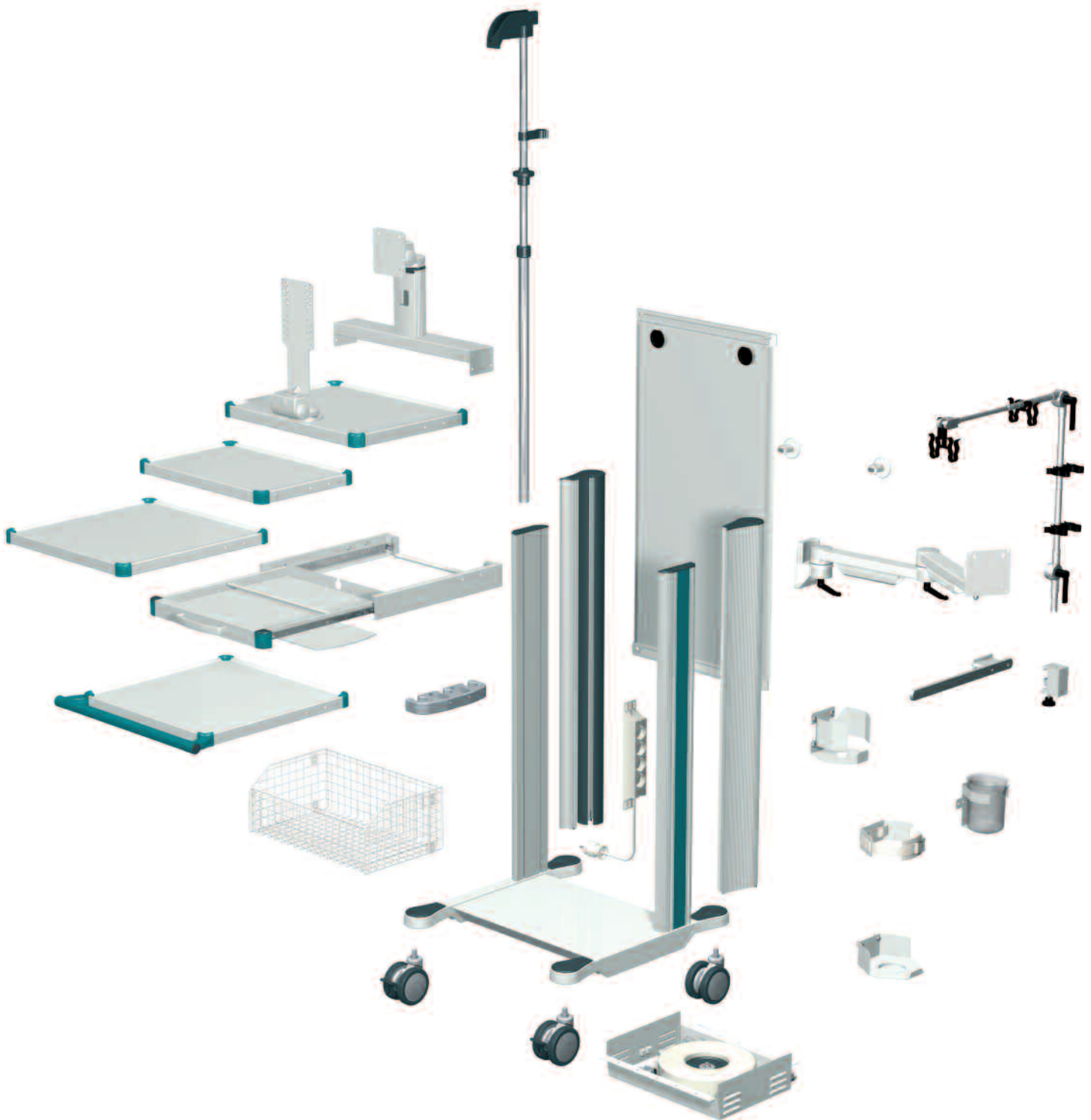

SEEK AND FIND!

TABLE OF CONTENTS



Basic frames 100

Basic frame uni-cart	100
Basic frame pro-cart	102
Basic frame classic-cart	103
Basic frame compact-cart	104
Basic frame endo-cart	106



Power columns 108

Rear panels / Rear doors 109

Castor conversion kit 111

Shelves 112

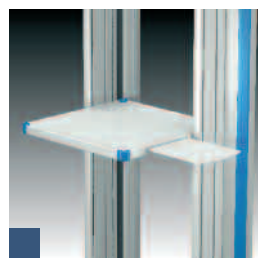

Keyboard drawers 119

Computer holders 121

Monitor holders 122

Drawers 132

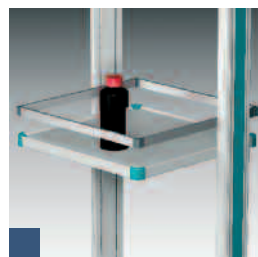

Baskets 136

Holders for medical accessories 138

Endoscope holder	139
Drain glass	140
Connector holder	140
Rinsing bottle holder	141
Hose holder	141
Camera holders	142
Gel bottle holder	143
Bottle holder	143
Gas bottle holder	144
Infusion stand	145
Standard runner	146
Anchor	146
Clamps	147
Holder for suction systems	148
Adapter pieces	149
Foot switch shelf	150
Holder for transducer	151
Box holder Dracula	151





Jointed arms **152**

Pivot arms for VESA-Standard	152
Variable height arms for VESA-Standard	153
Jointed arms	155



Handles **156**

Socket strips **158**

Socket strip mounting kits **166**

Power-Unit **167**



Plug removal barriers **168**

Cable winders **169**

Cables **170**



Equipotential bonding **172**

Isolating transformers **173**

Mounting hardware **178**

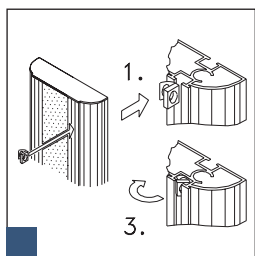

Order Number Index **180**

Keyword Index **182**

Note on ordering tables:

The coloured boxes highlight the relevant product line.

Products are suitable for uni-cart	Products are suitable for compact-cart
Products are suitable for pro-cart	Products are suitable for endo-cart
Products are suitable for classic-cart	

LOTS OF EXTRAS FOR ROUTINE, EVERYDAY USE

All system components and accessories were specifically developed for medical settings. This range of mobile and stationary ITD equipment carriers features logical and consistent compatibility combined with modularity. This means that each carrier system can be fitted to meet the challenges of routine, everyday operations. The range of accessories is so comprehensive that it is able to meet virtually any requirement.



Jointed arms with hose clamps



Infusion stand with 4-arm safety bottle holder



Variable height jointed arms for flat screens



Endoscope holders



Gas bottle holders



Rear doors (lockable) and rear panels

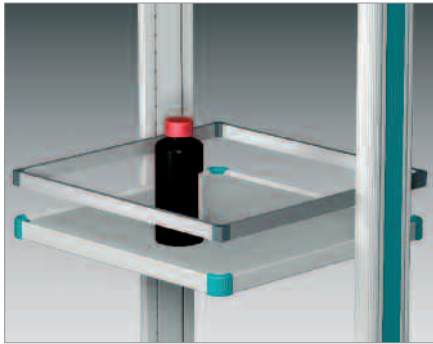

Continuous galleries



Drawers, roller-guided

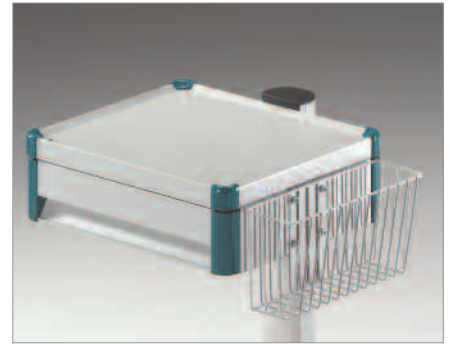

Baskets

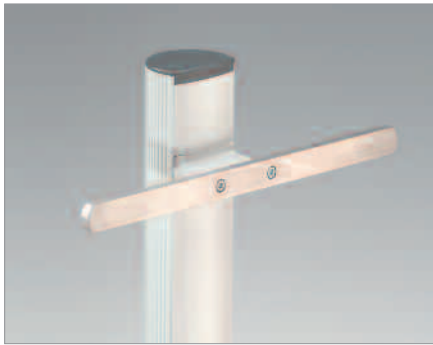

Standard runners



Socket strips conforming to the relevant guidelines

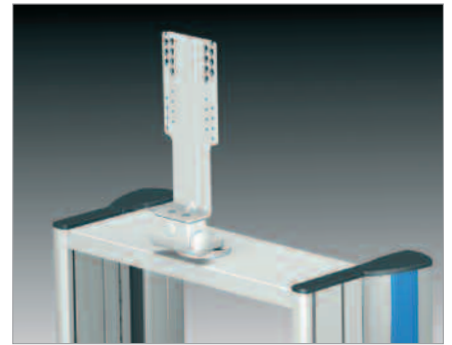

Monitor holders in different versions



Handles in different sizes and versions



Shelves

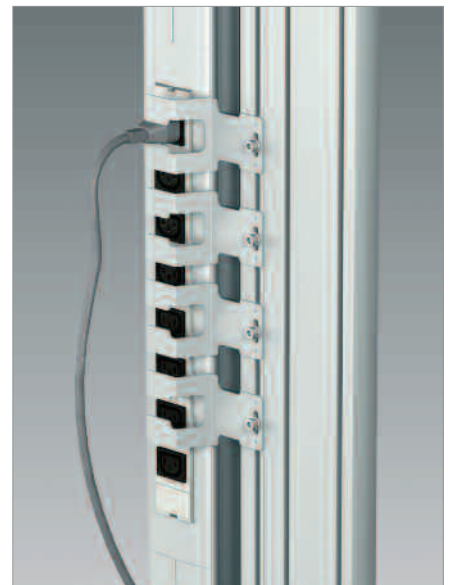

Plug removal barriers

BASIC FRAME uni-cart

Basic frame uni-cart (4 Stabilizers)

The basic frame **uni-cart** with 4 stabilizers provides a secure solution for mounting all projecting system modules, such as drawers and shelves, because the angle (6° increments) and length of the stabilizers can be adapted to suit individual requirements. This combination provides a high level of stability and flexibility. The basic frame is also resistant to twisting and has optimum tilt stability combined with a small footprint. The support column offers neat and concealed cable routing. An integrated strain relief protects outgoing cabling. Socket strips, infusion rods or monitor holders can also be easily integrated.

Load capacity: 50 kg / 110 lbs
Material: Aluminium / steel
Finish: RAL 7035 Light Grey powder-coated

Scope of delivery:

- 1 base unit with 4 stabilizers
- 4 twin swivel castors, 2 with wheel lock, with wall protector
- 1 support column
- 1 counterweight kit (only in **uni-cart** with 35 U¹⁾)

How supplied: Partly assembled

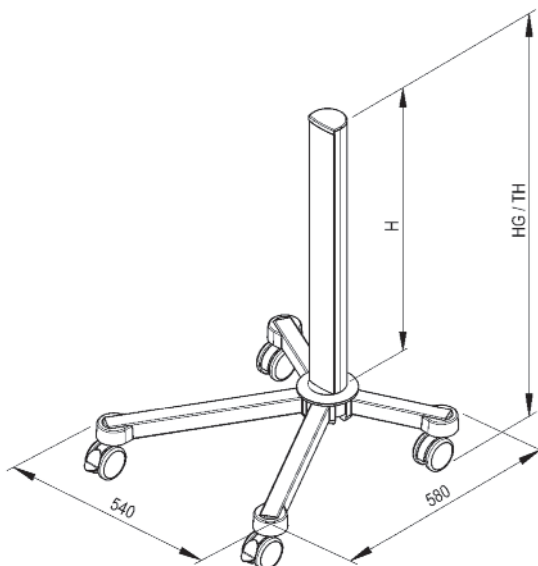

Note:

In order to guarantee maximum stability, we recommend that you check equipment carts with installed original equipment in conformity with EN60601 and order a counterweight kit as necessary.

	Installation height H	Total height TH	Castors	Order number
uni-cart basic frame with 4 stabilizers	21 U ¹⁾	820 mm	Ø 75 mm	RS.4008.991
	30 U ¹⁾	1145 mm	Ø 100 mm	RS.4011.991
	35 U ¹⁾	1305 mm	Ø 100 mm	RS.4027.991
Counterweight kit for 4 stabilizers (is integrated in the stabilizers at the factory)				RS.0344.999

¹⁾ 1 U = 32 mm

BASIC FRAME uni-cart

Basic frame uni-cart (5 stabilizers)

The basic frame **uni-cart** with 5 stabilizers is resistant to twisting and has a high tilt stability combined with a small footprint. The support column offers neat and concealed cable routing. An integrated strain relief protects outgoing cabling. Socket strips, infusion rods or monitor holders can also be easily integrated. The angle (6° increments) and length of the stabilizers can be adapted to suit individual requirements. This combination provides a high level of stability and flexibility. The basic frame with 5 stabilizers is ideal for centrally positioned payloads, e.g. attachment of a monitor holder, an infusion stand, a basket, standard runners or a gas bottle holder.

Load capacity: 50 kg / 110 lbs
Material: Aluminium / steel
Finish: RAL 7035 Light Grey powder-coated

Scope of delivery:

- 1 base unit with 5 stabilizers
- 5 twin swivel castors, 2 with wheel lock, with wall protector
- 1 support column
- 1 counterweight kit (only with **uni-cart** with 35 U¹⁾)

How supplied: Partly assembled

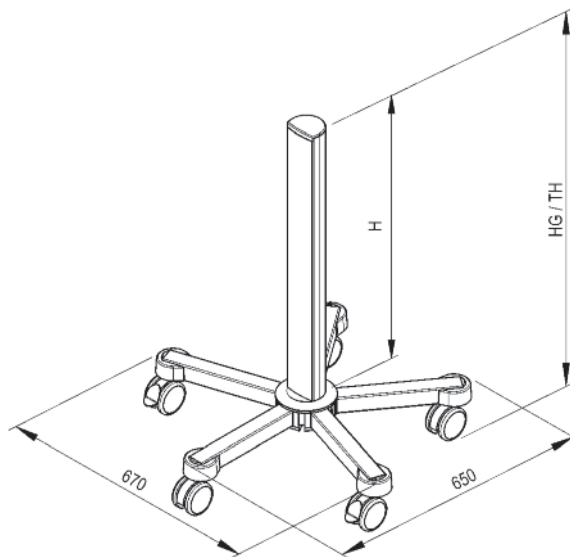

Note:

In order to guarantee maximum stability, we recommend that you check equipment carts with installed original equipment in conformity with EN60601 and order a counterweight kit as necessary.

	Installation height H	Total height TH	Castors	Order number
uni-cart basic frame with 5 stabilizers	21 U ¹⁾	820 mm	Ø 75 mm	RS.5008.991
	30 U ¹⁾	1145 mm	Ø 100 mm	RS.5011.991
	35 U ¹⁾	1305 mm	Ø 100 mm	RS.5024.991
Counterweight kit for 5 stabilizers (is integrated in the stabilizers at the factory)				RS.0349.999

¹⁾ 1 U = 32 mm



BASIC FRAME **pro-cart**

Basic frame **pro-cart**

The aluminium design of the basic frame **pro-cart** provides a high load rating despite low-weight construction. The design of the base guarantees a high level of resistance to twisting and space-saving integration of an isolating transformer (see page 174). The spacious support column delivers safe power supply and effective cable management. All standard socket strips can be accommodated with ease.

Load capacity: 80 kg / 176 lbs
Material: Aluminium
Finish: RAL 7035 Light Grey powder-coated
 Cover cap and cover strips in RAL 7043 Traffic Grey B

Scope of delivery:

- 1 base unit
- 4 twin swivel castors Ø 100 mm, 2 with wheel lock
- 1 support column

How supplied: Fully assembled

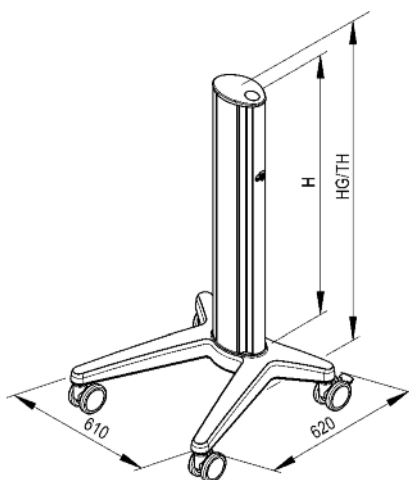

	Installation height H	Total height TH	Order number
pro-cart basic frame	21 U ¹⁾	884 mm	PT.4000.991
	30 U ¹⁾	1172 mm	PT.4001.991
	35 U ¹⁾	1332 mm	PT.4002.991

Basic trim for **pro-cart**

The stylish basic trim provides a design element and is positioned between the front stabilizers.

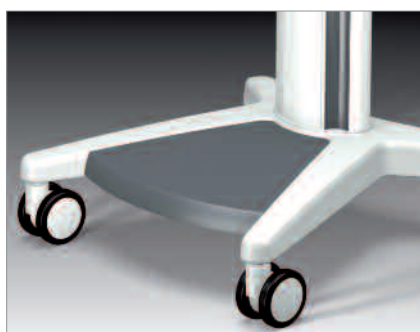

Load capacity: 5 kg / 11 lbs
Material: Plastic (ABS)
Finish: RAL 7043 Traffic Grey B
Scope of delivery: 1 basic trim with mounting hardware

	Product line	Order number
Basic trim	■	PT.2001.800

¹⁾ 1 U = 32 mm

BASIC FRAME classic-cart

Basic frame classic-cart Profi

The basic frame **classic-cart** Profi has a high level of resistance to twisting and high mounting capacity. The frame also offers lots of options for expansion and upgrading. Optional power columns (see page 108) offer separate routing for large volumes of power cables and data lines or integration of socket strips. The colours of the decorative trims can be matched to the equipment or corporate CI. There is also the option of fitting the equipment cart with a powerful isolating transformer (see page 175) and a rear panel (see page 109).

Load capacity: 150 kg / 330 lbs
Material: Aluminium / steel
Finish: RAL 7035 Light Grey powder-coated
Trim elements: See ¹⁾

Scope of delivery:

- 1 base unit
- 4 twin swivel castors (Ø 100 mm), 2 with wheel lock
- 2 vertical extrusions
- 2 decorative trims

How supplied: Fully assembled

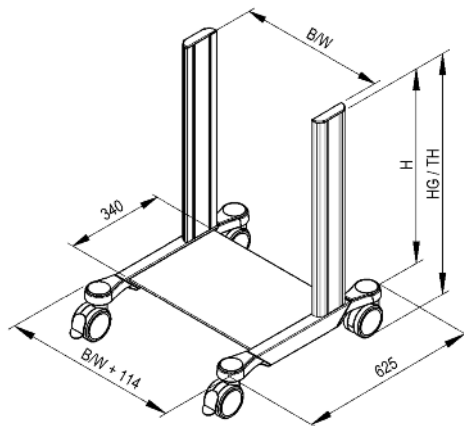

Note:

You will find power columns for the basic frame Profi on page 108!

	Installation height H	Total height TH	Order number for installation width	
			W 500 mm	W 600 mm
classic-cart basic frame Profi	21 U ²⁾	829 mm	GW.5502.XXX	GW.6502.XXX
	30 U ²⁾	1117 mm	GW.5503.XXX	GW.6503.XXX
	40 U ²⁾	1437 mm	GW.5504.XXX	GW.6504.XXX

¹⁾ **Trim colour:** Make sure you replace .XXX by .901 = RAL 5021 Water Blue, .902 = RAL 5013 Cobalt Blue, .903 = RAL 7035 Light Grey

²⁾ 1 U = 32 mm



BASIC FRAME compact-cart

Basic frame compact-cart Economy

The basic frame **compact-cart** Economy meets expectations for a functional, mobile equipment cart and has a high level of resistance to twisting. The design of the base also provides an optimum ratio of storage area to work area. Small cable volumes can easily be accommodated in the support columns.

Load capacity: 150 kg / 330 lbs
Material: Aluminium / steel
Finish: RAL 7035 Light Grey powder-coated

Scope of delivery:

- 1 base unit
- 4 twin swivel castors Ø 100 mm, 2 with wheel lock
- 2 vertical extrusions

How supplied: Fully assembled

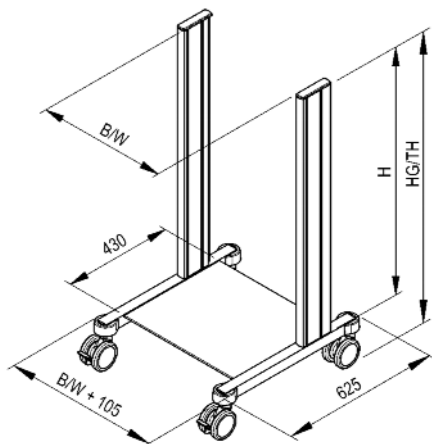

	Installation height H	Total height TH	Order number for installation width		
			W 450 mm	W 500 mm	W 650 mm
compact-cart basic frame Economy	21 U ¹⁾	839 mm	EB.4502.991	EB.5002.991	EB.6502.991
	30 U ¹⁾	1127 mm	EB.4503.991	EB.5003.991	EB.6503.991
	35 U ¹⁾	1287 mm	EB.4504.991	EB.5004.991	EB.6504.991
	40 U ¹⁾	1447 mm	EB.4505.991	EB.5005.991	EB.6505.991

¹⁾ 1 U = 32 mm

BASIC FRAME compact-cart

Basic frame compact-cart Profi

The basic frame **compact-cart** Profi has a high level of resistance to twisting. The projecting position of the castors guarantees outstanding tilt stability. The design of the base also guarantees an optimum ratio of storage area to work area. In addition to meeting the demands for a functional equipment cart, the spacious power columns of the basic frame Profi also provide expanded capacity for separate cable routing of large volumes of power cables and data lines, and accommodation of all standard socket strips. The result is safe power supply and effective cable management. The colours of integrated trims can be matched to the equipment or corporate CI. There is also the option of fitting the equipment cart with a powerful isolating transformer (see page 176) in the base.

Load capacity: 180 kg / 396 lbs
Material: Aluminium / steel
Finish: RAL 7035 Light Grey powder-coated
Trim elements: See ¹⁾

Scope of delivery:

- 1 base unit
- 4 twin swivel castors Ø 100 mm, 2 with wheel lock
- 2 vertical extrusions
- 2 power columns
- 2 decorative trims

How supplied: Fully assembled

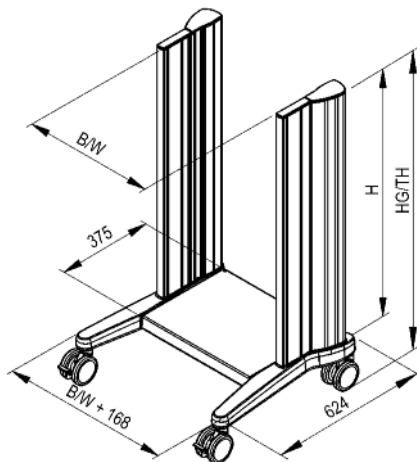

	Installation height H	Total height TH	Order number for installation width		
			W 450 mm	W 500 mm	W 650 mm
compact-cart basic frame Profi	30 U ²⁾	1146 mm	CC.4503.XXX	CC.5003.XXX	CC.6503.XXX
	35 U ²⁾	1306 mm	CC.4504.XXX	CC.5004.XXX	CC.6504.XXX
	40 U ²⁾	1466 mm	CC.4505.XXX	CC.5005.XXX	CC.6505.XXX

¹⁾ **Trim colour:** Make sure you replace .XXX by .903 = RAL 7035 Light Grey, .908 = RAL 5015 Sky Blue, .909 = RAL 1003 Signal Yellow

²⁾ 1 U = 32 mm



BASIC FRAME **endo-cart**

Basic frame **endo-cart**

The basic frame **endo-cart** has a high load capacity and stability. A continuous upper platform 1100 mm in width offers a large storage area. The base unit accommodates the vertical extrusions, the power columns and the centre column. The decorative trims are insertable in the vertical extrusions and provide options for a choice of individual colour and graphic design. The basic frame also gives the option of integrating a powerful isolating transformer (see page 175) and optionally lift-out rear panels (see page 109).



- Load capacity:** 150 kg / 330 lbs
Material: Aluminium / steel
Finish: RAL 7035 Light Grey powder-coated
Trim elements: See ¹⁾
Scope of delivery:
- 1 base unit
 - 4 twin swivel castors Ø 100 mm, conductive, 2 with wheel locks
 - 2 vertical extrusions 30 U²⁾
 - 2 power columns 30 U²⁾
 - 1 centre column as cable duct
 - continuous upper shelf, each with a handle left and right
- How supplied:** Fully assembled

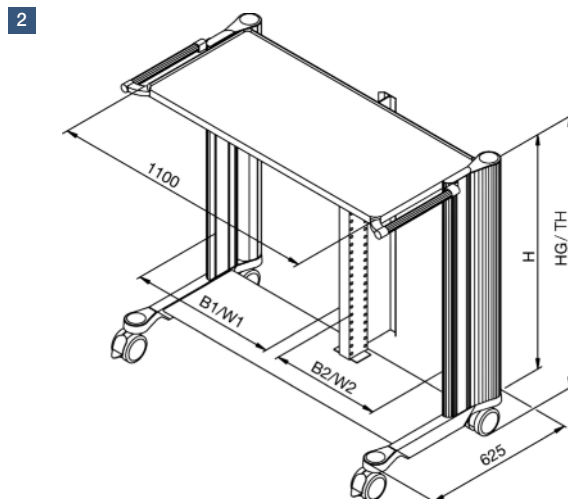
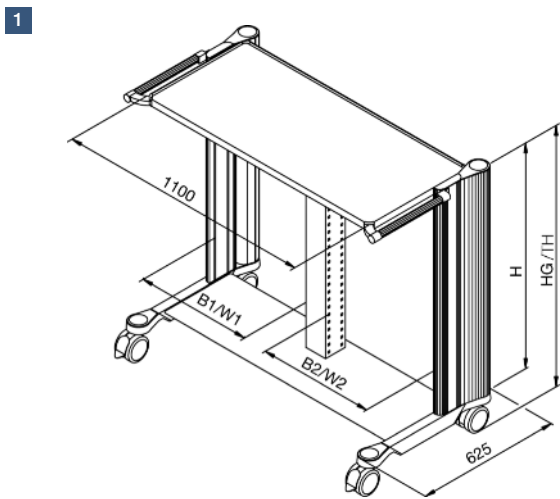

Note:

See page 109 for rear panels for basic frame **endo-cart**.

endo-cart basic frame	Installation height H	Total height TH	Installation widths W1 / W2	Order number
1 Symmetrical width division	30 U ²⁾	1117 mm	500 / 500 mm	EC.0400.XXX
2 Asymmetrical width division	30 U ²⁾	1117 mm	450 / 600 mm	EC.0402.XXX
	30 U ²⁾	1117 mm	600 / 450 mm	EC.0403.XXX

¹⁾ **Trim colour:** Make sure you replace .XXX by .901 = RAL 5021 Water Blue, .902 = RAL 5013 Cobalt Blue, .903 = RAL 7035 Light Grey

²⁾ 1 U = 32 mm

BASIC FRAME **endo-cart**

Basic frame **endo-cart** (with extended vertical extrusion)

The basic frame **endo-cart** with extended vertical extrusions and standard runner (L 1100 mm) offers the advantage of the basic version combined with the opportunity to mount additional accessories, e.g. multipurpose boxes, in a space-saving configuration. The decorative trims insertable in the vertical extrusions provide options for a choice of individual colour and graphic design.



Load capacity: 150 kg / 330 lbs

Material: Aluminium / steel

Finish: RAL 7035 Light Grey powder-coated

Trim elements: See ¹⁾

Scope of delivery:

- 1 base unit
- 4 twin swivel castors Ø 100 mm, conductive, 2 with wheel locks
- 2 vertical extrusions 40 U²⁾
- 2 power columns 30 U²⁾
- 1 centre column as cable duct
- continuous upper shelf, each with a handle left and right
- 1 standard runner

How supplied: Fully assembled

1

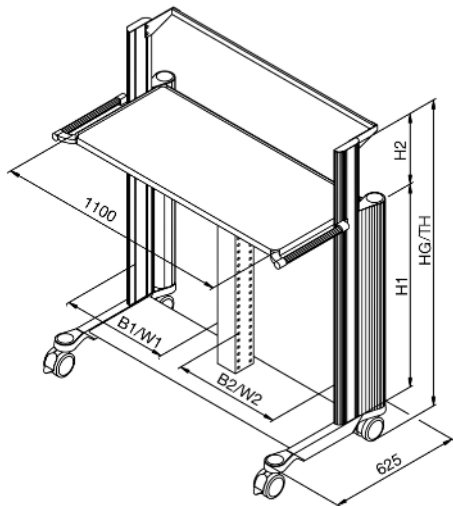

2

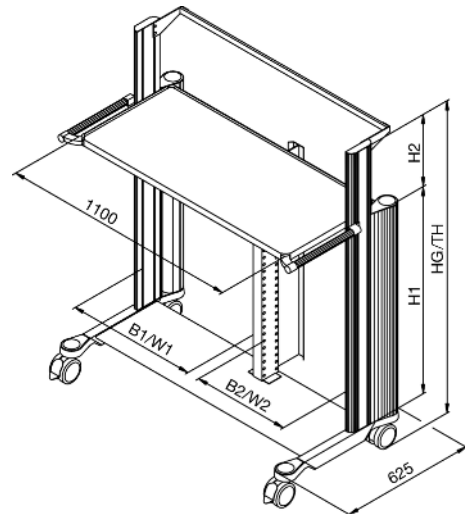

Note:

See page 109 for rear panels for basic frame **endo-cart**.

endo-cart basic frame with extended vertical extrusion	Installation height H1 + H2	Total height TH	Installation widths W1 / W2	Order number
1 Symmetrical width division	30 U + 10 U ²⁾	1437 mm	500 / 500 mm	EC.0401.XXX
2 Asymmetrical width division	30 U + 10 U ²⁾	1437 mm	450 / 600 mm	EC.0404.XXX
	30 U + 10 U ²⁾	1437 mm	600 / 450 mm	EC.0405.XXX

¹⁾ **Trim colour:** Make sure you replace .XXX by .901 = RAL 5021 Water Blue, .902 = RAL 5013 Cobalt Blue, .903 = RAL 7035 Light Grey

²⁾ 1 U = 32 mm



POWER COLUMNS

Power columns for classic-cart basic frame Profi

The aluminium extrusion with two spacious cable shafts offers lots of storage space for cable management. Power cables and data lines can be routed separately to individual units. This means socket strips can be enclosed and integrated over the full height of the columns. Continuous soft cover extrusions protect cabling. Quick-release cable ties provide fast cable fixing.

Power columns can also be supplied with a cutout for installing a central on/off switch. This is a convenient option for switching all equipment on or off. The switch is installed in the right-hand power column and is necessary for accommodating isolating transformers, socket strips, etc.

- Material:** Extruded aluminium
- Finish:** RAL 7035 Light Grey powder-coated
- Scope of delivery:** 2 power columns with mounting hardware

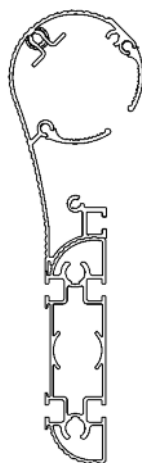

classic-cart

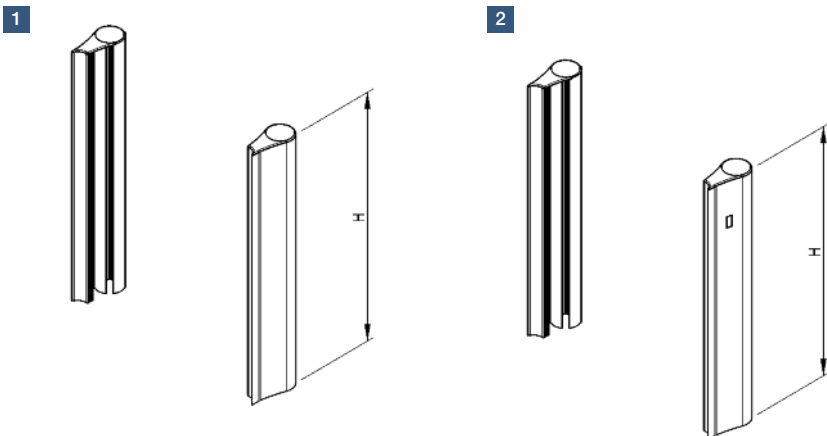

	Installation height H	Product line	Order number	
			without preparation for on / off switch 1	with preparation for on / off switch 2
Power columns for classic-cart basic frame Profi	21 U ¹⁾	■	GW.0242.991	GW.0660.991
	30 U ¹⁾	■	GW.0243.991	GW.0661.991
	40 U ¹⁾	■	GW.0244.991	GW.0662.991

¹⁾ 1 U = 32 mm

System components and accessories

REAR PANELS

Rear panel for **classic-cart** basic frame Profi

The rear panel can be removed with two quick fasteners. It protects equipment against unauthorized access and offers fast access to units for assembly and service operations.

- Material:** Sheet steel
Finish: RAL 7035 Light Grey powder-coated
Scope of delivery: 1 rear panel with mounting hardware
How supplied: Factory assembly only

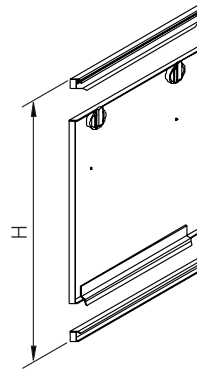

Note:

- Rear panels can only be used in combination with power columns (see page 108)!
- Rear doors can be supplied on request!

	Installation height H	Product line	Order number for installation width	
			W 500 mm	W 600 mm
Rear panel for classic-cart basic frame Profi	21 U ¹⁾	■	GW.5150.991	GW.6150.991
	30 U ¹⁾	■	GW.5151.991	GW.6151.991
	40 U ¹⁾	■	GW.5152.991	GW.6152.991

Rear panel for **endo-cart** basic frame

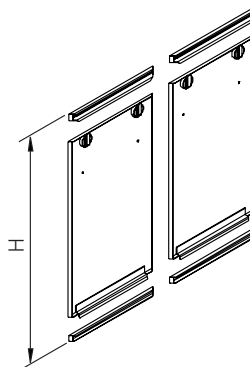

- Material:** Sheet steel
Finish: RAL 7035 Light Grey powder-coated
Scope of delivery: 2 rear panels, incl. mounting hardware
How supplied: Factory assembly only

Rear panel for endo-cart basic frame	Division of widths	Installation height H	Product line	Order number
for symmetrical width division	500 mm / 500 mm	30 U ¹⁾	■	GW.8050.991
for asymmetrical width division	600 mm / 450 mm	30 U ¹⁾	■	GW.8051.991

¹⁾ 1 U = 32 mm

REAR DOORS

Rear doors for **compact-cart** basic frame Profi

The lockable rear doors offer optimum protection against unauthorized access at the rear side of equipment and also provide a perfect solution from hygienic and visual perspectives. The large opening angle (135°) of the doors provides unimpeded access to the rear side of the equipment for maintenance and service operations. The door can also easily be removed if required.

- Material:** Sheet steel
Finish: RAL 7035 Light Grey powder-coated
Scope of delivery: 1 double door
 1 cross connector
 with mounting hardware
How supplied: Pre-assembled

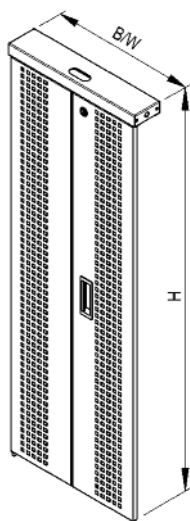

	Installation height H	Product line	Order number for installation width		
			W 450 mm	W 500 mm	W 650 mm
Rear doors for compact-cart basic frame Profi	30 U ¹⁾	■	CC.4560.991	CC.5060.991	CC.6560.991
	35 U ¹⁾	■	CC.4561.991	CC.5061.991	CC.6561.991
	40 U ¹⁾	■	CC.4562.991	CC.5062.991	CC.6562.991

¹⁾ 1 U = 32 mm

CASTOR CONVERSION KIT

Castor conversion kit

ITD equipment carts come as standard fitted with Ø 75 mm or Ø 100 mm castors. The castors have a medium coating hardness and are therefore suitable for all floor coverings. We also supply the following castors – in each case supplied as a castor conversion kit instead of the standard version described:

- 1 Ø 100 mm, conductive or non-conductive; with wheel lock
 - 2 Ø 100 / Ø 125 mm, conductive; with wheel lock
 - 3 Wall protector (soft polyethylene wheels Ø 100 mm) suitable for castors Ø 100 mm and Ø 125 mm
- Scope of delivery:** 4 bumper wheels, 4 spacers

Load capacity per castor:

- Ø 100 mm: 75 kg / 164 lbs
- Ø 125 mm: 100 kg / 220 lbs

Note:

Please note the maximum load rating of each basic frame.

The following applies for all basic frames:

Scope of delivery: 1 castor conversion kit (4 castors, including 2 castors with wheel lock)
How supplied: Factory assembly only

The following applies to the uni-cart basic frame with 5 stabilizers:

Scope of delivery: 1 castor conversion kit (5 castors, 2 castors with wheel lock)
How supplied: Factory assembly only



Castor conversion kit	Instead of standard	Product line	Order number	
			Basic frame/4	Basic frame/5
1 Ø 100 mm	Ø 75 mm	■	ZV.9920.999	ZV.9926.999
1 Ø 100 mm, conductive	Ø 75 mm	■	ZV.9921.999	ZV.9927.999
1 Ø 100 mm, conductive	Ø 100 mm	■	ZV.9922.999	ZV.9929.999
1 Ø 100 mm, conductive	Ø 100 mm	■ ■	ZV.9922.999	
2 Ø 100 mm, conductive	Ø 100 mm	■ ■	ZV.9428.999	
2 Ø 125 mm, conductive	Ø 100 mm	■ ■ ■ ■	ZV.9923.999	
2 Ø 125 mm, conductive	Ø 100 mm, conductive	■ ■ ■ ■	ZV.9924.999	
3 Wall protector		■ ■ ■ ■ ■	ZV.9964.999	

SHELVES

The shelves have the following features:

- The continuous raised edge provides a secure platform for valuable medical equipment.
- The rounded corners protect users from injuries.
- The corners are an important design element¹⁾ offering a choice of colours. They play a key role in defining the CI of the customer.
- The low installation height of only 32 mm saves installation space and creates valuable work space.
- The powder-coated finish is easy to clean and resistant to cleaning agents and disinfectants.

Shelves for uni-cart

The shelves for **uni-cart** are supplied in different versions:

- 1 Shelf
- 2 Shelf with handle
- 3 Shelf with mousepad
- 4 Shelf with handle and mousepad (not shown)

Material: Sheet steel
Assembly: In the front T-slots of the support column
Platform area: 400 mm x 360 mm (W x D)
Load capacity: 10 kg / 22 lbs (distributed load)
Finish: RAL 7035 Light Grey powder-coated, trim elements see ¹⁾
Scope of delivery: 1 shelf incl. bracket and mounting hardware
How supplied: Pre-assembled

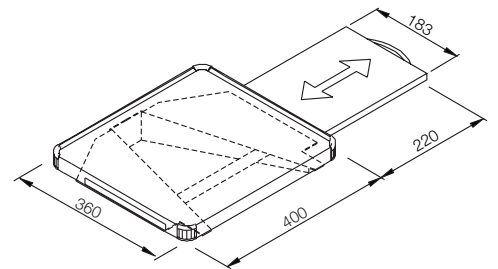
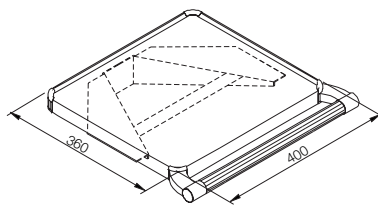
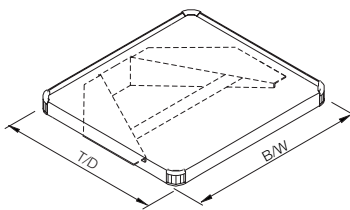
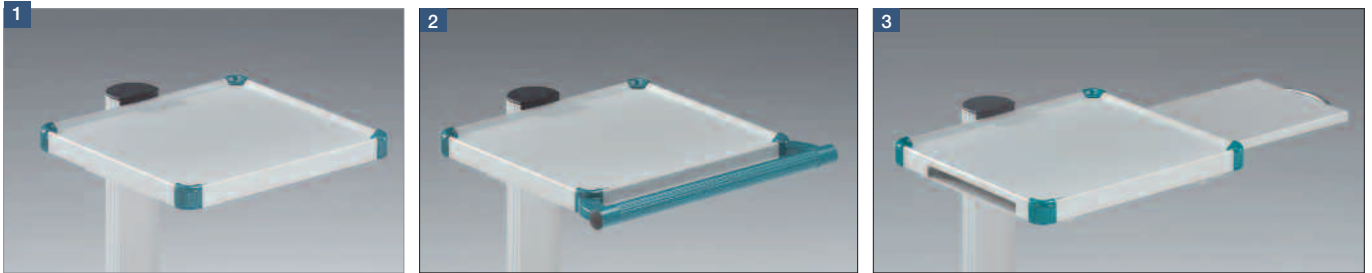

Note:

The mousepad can be pulled out to the right. On request, a left-hand pullout can be supplied.

Shelves for uni-cart	Dimensions W x D (mm)	Installation height	Product line	Order number
1 Shelf	400 x 360	3 U ²⁾	■	RS.4360.XXX
2 Shelf with handle	400 x 360	3 U ²⁾	■	RS.4361.XXX
3 Shelf with mousepad	400 x 360	3 U ²⁾	■	RS.4370.XXX
4 Shelf with handle and mousepad (not shown)	400 x 360	3 U ²⁾	■	RS.4372.XXX

¹⁾ **Trim colour:** Make sure you replace .XXX by .901 = RAL 5021 Water Blue, .902 = RAL 5013 Cobalt Blue, .903 = RAL 7035 Light Grey

²⁾ 1 U = 32 mm

Shelves for **pro-cart**

Shelves for **pro-cart** are supplied in different versions:

- 1 Shelf
- 2 Shelf with handle
- 3 Shelf with mousepad, pulls out to left and right
- 4 Shelf with mousepad and handle

Material: Aluminium
Assembly: In the front T-slots of the support column
Platform area: 450 mm x 360 mm (W x D)
Load capacity: 20 kg / 44 lbs (distributed load)
Finish: RAL 7035 Light Grey powder-coated, trim elements see ¹⁾
Scope of delivery: 1 shelf with mounting hardware
How supplied: Pre-assembled

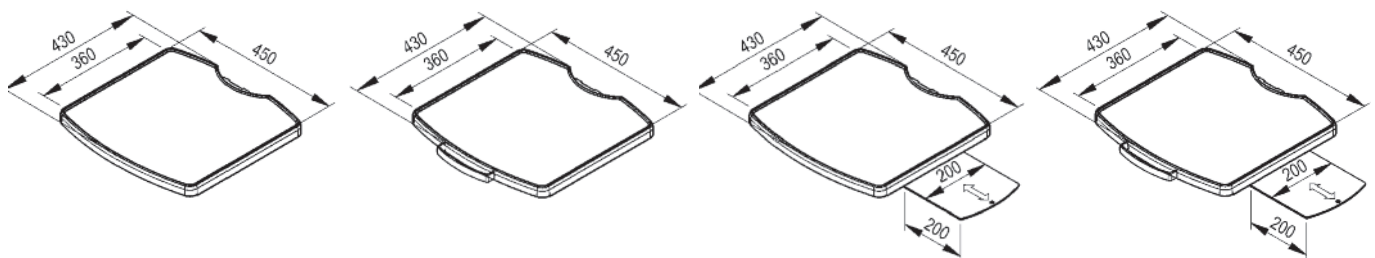
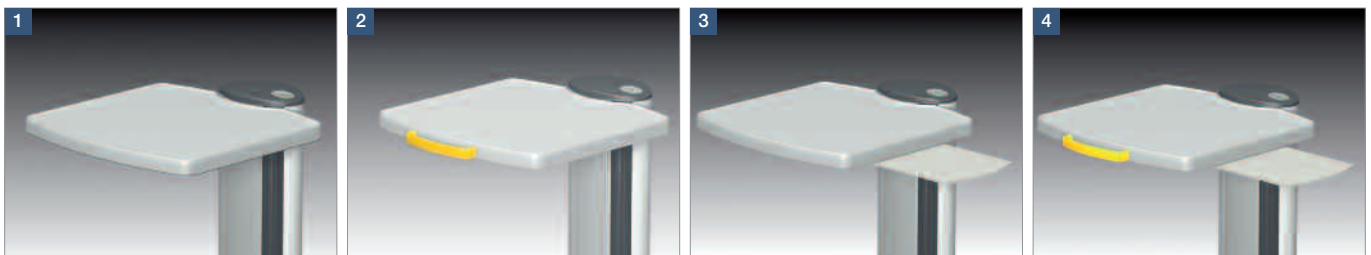

Shelves for pro-cart	Installation height	Product line	Order number
1 Shelf	1 U ²⁾	■	PT.4100.991
2 Shelf with handle	1 U ²⁾	■	PT.4101.XXX
3 Shelf with mousepad	1 U ²⁾	■	PT.4102.991
4 Shelf with handle and mousepad	1 U ²⁾	■	PT.4103.XXX

¹⁾ **Trim colour:** Make sure you replace .XXX by .903 = RAL 7035 Light Grey, .908 = RAL 5015 Sky Blue, .909 = RAL 1003 Signal Yellow

²⁾ 1 U = 32 mm

SHELVES

Shelves for classic-cart and endo-cart

Shelves for **classic-cart** and **endo-cart** are supplied in different versions:

- 1 Shelf
- 2 Shelf with push/lift handle
- 3 Shelf with mousepad, pulls out to left and right
- 4 Shelf with mousepad and handle

Material: Sheet steel
Platform area: 450 mm x 491 mm (W x D), for installation width 450 mm
 500 mm x 491 mm (W x D), for installation width 500 mm
 600 mm x 491 mm (W x D), for installation width 600 mm
Load capacity: 50 kg / 110 lbs (distributed load, without mousepad)
 10 kg / 22 lbs (distributed load, with mousepad)
Finish: RAL 7035 Light Grey powder-coated, trim elements see ¹⁾
Scope of delivery: 1 shelf, with mounting hardware
How supplied: Pre-assembled

classic-cart

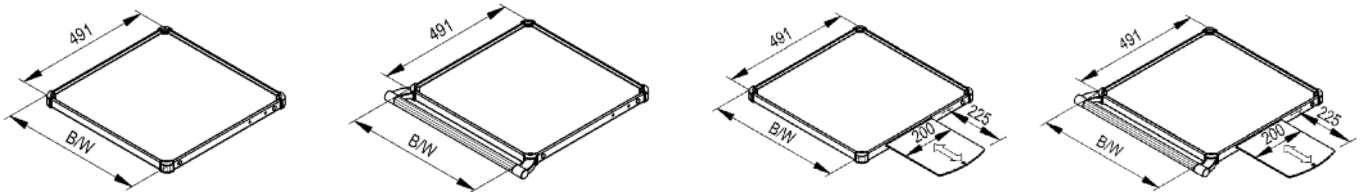
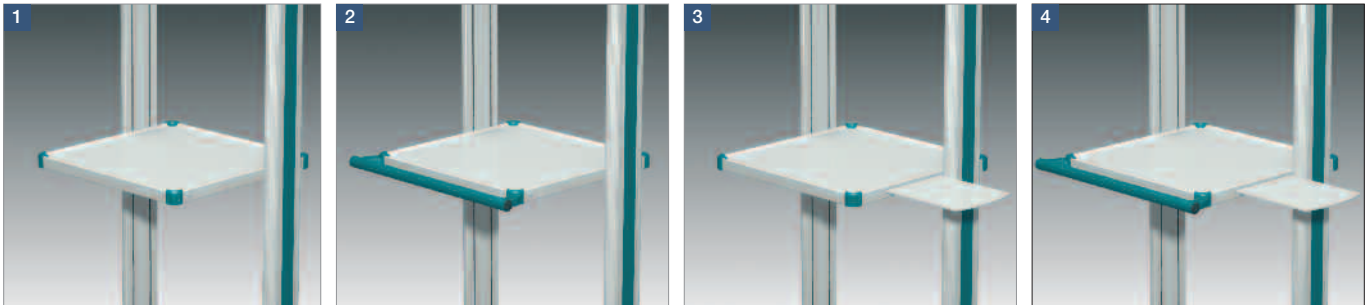

endo-cart

System components and accessories

Shelves	Installation height	Product line	Order number for installation width		
			W 450 mm	W 500 mm	W 600 mm
1 Shelf	1 U ²⁾		GW.4001.XXX	GW.5001.XXX	GW.6001.XXX
2 Shelf with handle	1 U ²⁾		GW.4002.XXX	GW.5002.XXX	GW.6002.XXX
3 Shelf with mousepad	1 U ²⁾		GW.4035.XXX	GW.5035.XXX	GW.6035.XXX
4 Shelf with mousepad and handle	1 U ²⁾		GW.4049.XXX	GW.5049.XXX	GW.6049.XXX

¹⁾ **Trim colour:** Make sure you replace .XXX by .901 = RAL 5021 Water Blue, .902 = RAL 5013 Cobalt Blue, .903 = RAL 7035 Light Grey

²⁾ 1 U = 32 mm

Shelves for compact-cart

Shelves for **compact-cart** are supplied in different versions:

- 1 Shelf
- 2 Shelf with push/lift handle
- 3 Shelf with side handles
- 4 Shelf with mousepad, pulls out to left and right
- 5 Shelf with mousepad and push/lift handle (not shown)

Material: Sheet steel

Platform area: 450 mm x 491 mm (W x D), for installation width 450 mm
 500 mm x 491 mm (W x D), for installation width 500 mm
 650 mm x 491 mm (W x D), for installation width 650 mm

Load capacity: 50 kg / 110 lbs (distributed load)

Finish: RAL 7035 Light Grey powder-coated, trim elements see ¹⁾

Scope of delivery: 1 shelf with mounting hardware

How supplied: Pre-assembled

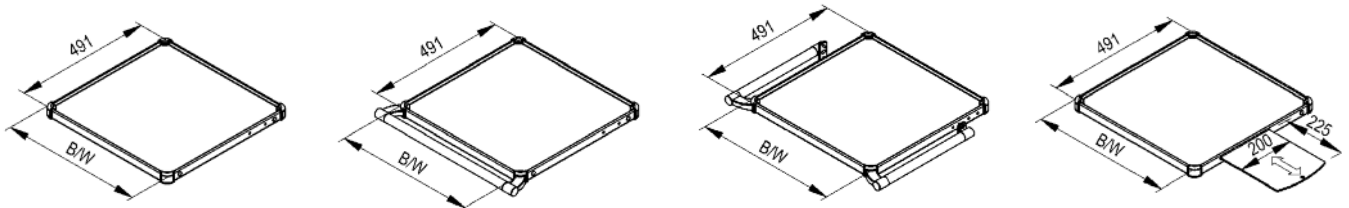
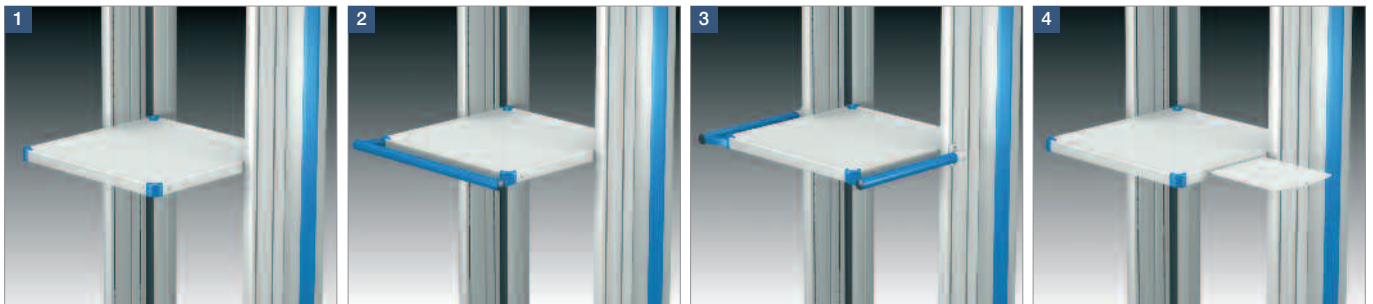

Shelves	Installation height	Product line	Order number for installation width		
			W 450 mm	W 500 mm	W 650 mm
1 Shelf	1 U ²⁾	■	CC.4520.XXX	CC.5020.XXX	CC.6520.XXX
2 Shelf with push/lift handle	1 U ²⁾	■	CC.4521.XXX	CC.5021.XXX	CC.6521.XXX
3 Shelf with side handles	1 U ²⁾	■	CC.4524.XXX	CC.5024.XXX	CC.6524.XXX
4 Shelf with mousepad	1 U ²⁾	■	CC.4522.XXX	CC.5022.XXX	CC.6522.XXX
5 Shelf with mousepad /handle (not shown)	1 U ²⁾	■	CC.4523.XXX	CC.5023.XXX	CC.6523.XXX

¹⁾ **Trim colour:** Make sure you replace .XXX by .903 = RAL 7035 Light Grey, .908 = RAL 5015 Sky Blue, .909 = RAL 1003 Signal Yellow

²⁾ 1 U = 32 mm

SHELVES

Shelf (depth 320 mm) for **classic-cart** and **compact-cart**

This shelf is suitable for accommodating small items of medical equipment or monitors and saving space at the same time. The narrow depth facilitates ease of access to the shelf below.

- Material:** Sheet steel
Platform area: 450 mm x 320 mm (W x D), for installation width 450 mm
 500 mm x 320 mm (W x D), for installation width 500 mm
 600 mm x 320 mm (W x D), for installation width 600 mm
 650 mm x 320 mm (W x D), for installation width 650 mm
Load capacity: 50 kg / 110 lbs (distributed load)
Finish: RAL 7035 Light Grey powder-coated, trim elements see ¹⁾
Scope of delivery: 1 shelf with mounting hardware
How supplied: Pre-assembled

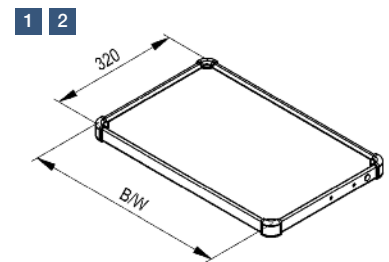
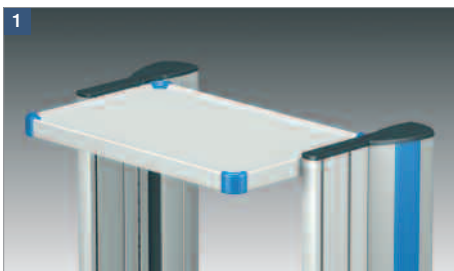

Shelf	Installation height	Product line	Order number for installation width			
			W 450 mm	W 500 mm	W 600 mm	W 650 mm
1 Depth 320 mm	1 U ²⁾		CC.4528.XXX	CC.5028.XXX		CC.6528.XXX
2 Depth 320 mm	1 U ²⁾			GW.5025.XXX	GW.6025.XXX	

Printer shelf for **classic-cart**

The spacious flat shelf with no raised edge allows paper trays to be withdrawn easily.

- Material:** Sheet steel
Load capacity: 15 kg / 33 lbs (distributed load)
Finish: RAL 7035 Light Grey powder-coated, trim elements see ¹⁾
Scope of delivery: 1 printer shelf with mounting hardware
How supplied: Pre-assembled

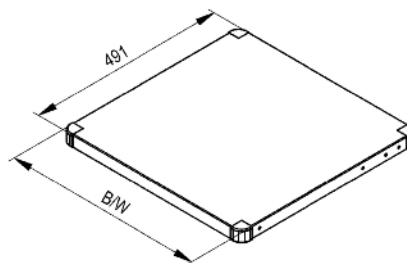
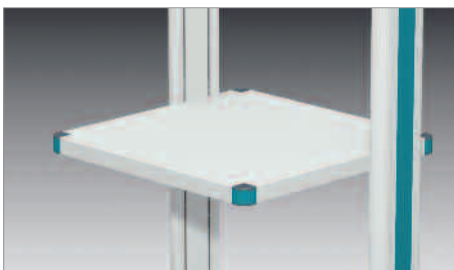

Printer shelf	Installation height	Product line	Order number	
			W 500 mm	W 600 mm
	1 U ²⁾		GW.5008.XXX	GW.6008.XXX

¹⁾ **Trim colour:** Make sure you replace in **compact-cart** .XXX by .903 = RAL 7035 Light Grey, .908 = RAL 5015 Sky Blue, .909 = RAL 1003 Signal Yellow
 Make sure you replace in **classic-cart** .XXX by .901 = RAL 5021 Water Blue, .902 = RAL 5013 Cobalt Blue, .903 = RAL 7035 Light Grey

²⁾ 1 U = 32 mm

Rack base for uni-cart and classic-cart

The rack base provides a cost-effective option, e.g. for mounting printers, directly on the base of the equipment cart.

- Material:** Sheet steel
Load capacity: 20 kg / 44 lbs (distributed load)
Finish: RAL 7035 Light Grey powder-coated
Scope of delivery: 1 rack base with mounting hardware
How supplied: Factory assembly only

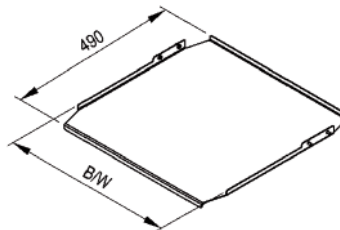
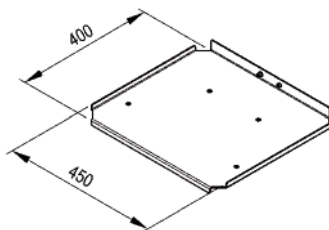
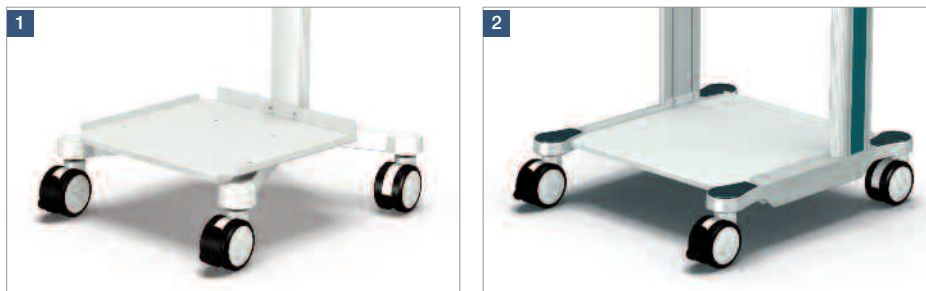

Rack base	Installation height	Product line	Order number for installation width		
			W 450 mm	W 500 mm	W 600 mm
1 Installation depth 400 mm	1 U ²⁾		RS.0143.991		
2 Installation depth 490 mm	1 U ²⁾		GW.4075.991	GW.5075.991	GW.6075.991

Side shelf with bracket for classic-cart and endo-cart

The shelf and bracket can be mounted on the side of the vertical extrusion (left or right). The shelf offers additional storage space. The height can be variably adjusted along the vertical extrusion.

- Material:** Sheet steel
Load capacity: 10 kg / 22 lbs (distributed load)
Finish: RAL 7035 Light Grey powder-coated, trim elements see ¹⁾
Scope of delivery: 1 shelf with bracket, with mounting hardware

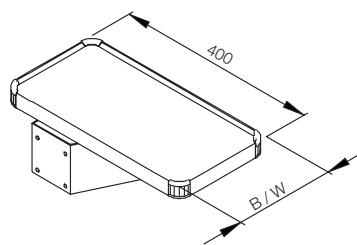

Side shelf	Installation height	Product line	Order number	
			W 200 mm	W 300 mm
right, installation depth 400 mm	4 U ²⁾		GW.0238.XXX	GW.0239.XXX
left, installation depth 400 mm	4 U ²⁾		GW.0248.XXX	GW.0249.XXX

¹⁾ **Trim colour:** Make sure you replace .XXX by .901 = RAL 5021 Water Blue, .902 = RAL 5013 Cobalt Blue, .903 = RAL 7035 Light Grey

²⁾ 1 U = 32 mm

SHELVES

Shelf pullout for **classic-cart** and **endo-cart**

The pullout shelf permits fast access to your equipment for assembly and servicing. It can also be used as a keyboard shelf or writing shelf. The pullout measures 265 mm and permits unrestricted access from all sides to the installed equipment. Detent points in the open or closed position allow the shelf to be fixed in these positions. The handle at the front makes it easier to move the shelf in and out.

- Material:** Sheet steel
- Load capacity:** 20 kg / 44 lbs (distributed load)
- Finish:** RAL 7035 Light Grey powder-coated, trim elements see 1)
- Scope of delivery:** 1 shelf with mounting hardware
- How supplied:** Pre-assembled

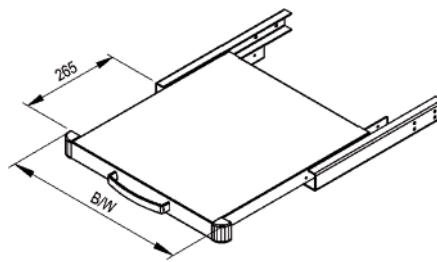
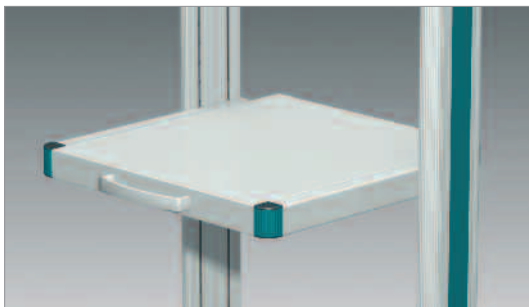

	Installation height	Product line	Order number for installation width		
			W 450 mm	W 500 mm	W 600 mm
Shelf pullout	1.5 U ²⁾		GW.4040.XXX	GW.5040.XXX	GW.6040.XXX

Universal shelf for **pro-cart**

This shelf can be adapted to the contour of the equipment being positioned on request.

- Material:** Aluminium / sheet steel
- Load capacity:** 10 kg / 22 lbs (distributed load)
- Finish:** RAL 7035 Light Grey powder-coated
- Scope of delivery:** 1 universal shelf with bracket, with mounting hardware
- How supplied:** Pre-assembled

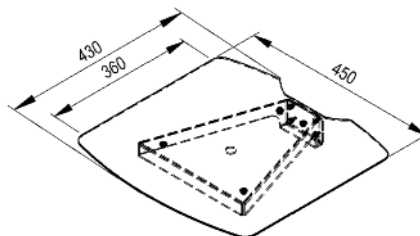
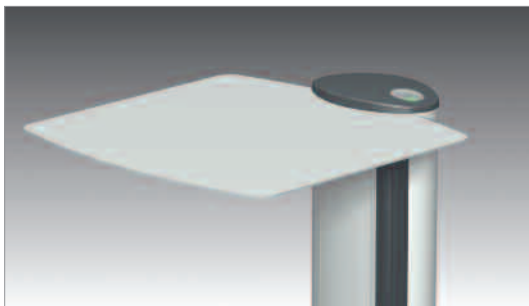

	Dimensions W x D (mm)	Installation height	Product line	Order number
Universal shelf for pro-cart	450 x 360	2 U ²⁾		PT.4111.991

1) **Trim colour:** Make sure you replace .XXX by .901 = RAL 5021 Water Blue, .902 = RAL 5013 Cobalt Blue, .903 = RAL 7035 Light Grey

2) 1 U = 32 mm

KEYBOARD DRAWERS

The keyboard drawer has the following features:

- The low installation height saves installation space and creates valuable work space.
- Adjustable bars or struts, depending on the model, prevent the keyboard from sliding when the shelf is moved.
- Cables are routed safely and protected against possible damage when the keyboard is moved in and out.
- The powder-coated finish is easy to clean and resistant to cleaning agents and disinfectants.
- The latch mechanism enhances user convenience and security in the open and closed position

Keyboard drawer with / without mousepad

The keyboard drawer has a low installation depth of 2 U²⁾. Two small keyboards can be positioned behind each other when fully extended (345 mm). An adjustable strut prevents the keyboard from sliding when the shelf is moved.

Material: Sheet steel

Dimensions: Cart with an installation width of 450 mm: keyboard width max. 407 mm
 Cart with an installation width of 500 mm: keyboard width max. 457 mm
 Cart with an installation width of 600 mm: keyboard width max. 557 mm
 Cart with an installation width of 650 mm: keyboard width max. 607 mm
 Keyboard depth: max. 320 mm
 Keyboard height: max. 49 mm

Load capacity: 5 kg / 11 lbs (distributed load)

Finish: RAL 7035 Light Grey powder-coated, trim elements see ¹⁾

Scope of delivery: 1 keyboard drawer with adjustable bar, with mounting hardware.

How supplied: Pre-assembled

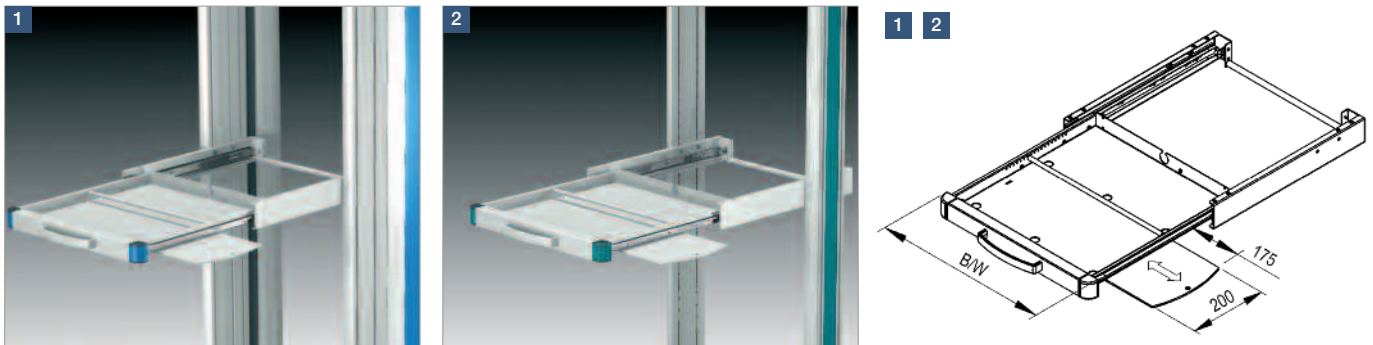

Keyboard drawer	Mouse-pad	Installation height	Product line	Order number for installation width			
				W 450 mm	W 500 mm	W 600 mm	W 650 mm
¹ Installation depth 491 mm	with	2 U ²⁾		CC.4550.XXX	CC.5050.XXX		CC.6550.XXX
² Installation depth 491 mm	without	2 U ²⁾		GW.4034.XXX	GW.5034.XXX	GW.6034.XXX	
	with	2 U ²⁾			GW.5036.XXX	GW.6036.XXX	

¹⁾ **Trim colour:** Make sure you replace in **compact-cart**

.XXX by .903 = RAL 7035 Light Grey, .908 = RAL 5015 Sky Blue, .909 = RAL 1003 Signal Yellow

Make sure you replace in **classic-cart** and **endo-cart** .XXX by .901 = RAL 5021 Water Blue, .902 = RAL 5013 Cobalt Blue, .903 = RAL 7035 Light Grey

²⁾ 1 U = 32 mm



KEYBOARD DRAWERS

Keyboard drawer for **pro-cart**

The keyboard drawer for keyboards up to 200 mm in depth has a low installation height of 3 U¹⁾. Two adjustable bars prevent the keyboard from sliding when the drawer is moved. The extension length is 260 mm and facilitates ergonomic working.

- Material:** Sheet steel
- Load capacity:** 3 kg / 6.6 lbs (distributed load)
- Finish:** RAL 7035 Light Grey powder-coated
- Scope of delivery:** 1 keyboard drawer, with mounting hardware
- How supplied:** Pre-assembled

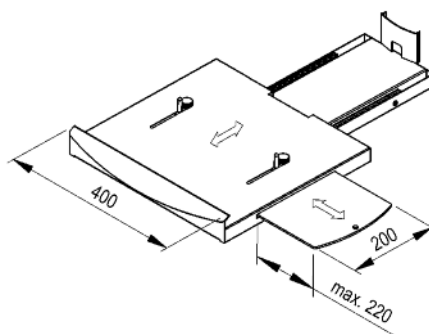
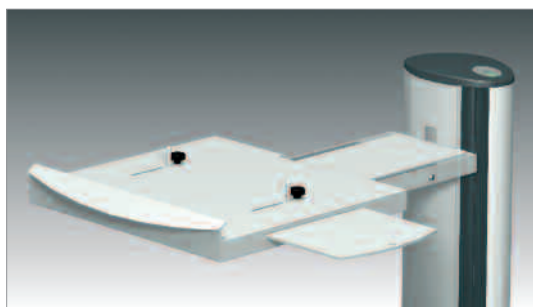

	Installation height	Product line	Order number
Keyboard drawer	3 U ¹⁾	■	PT.4108.991

Keyboard holder for **uni-cart**

The keyboard holder is suitable for drawers with a width of 400 mm. It is used to position narrow keyboards (width: 290 mm) inside the drawer.

- Material:** Sheet steel
- Finish:** RAL 7035 Light Grey powder-coated
- Scope of delivery:** 1 keyboard holder (for installation in existing drawer)

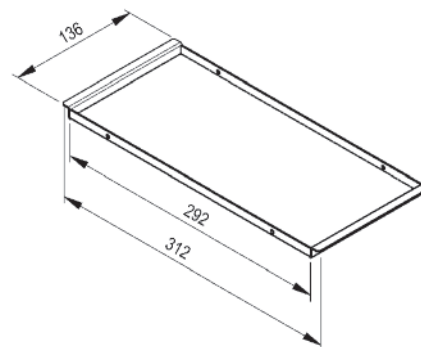
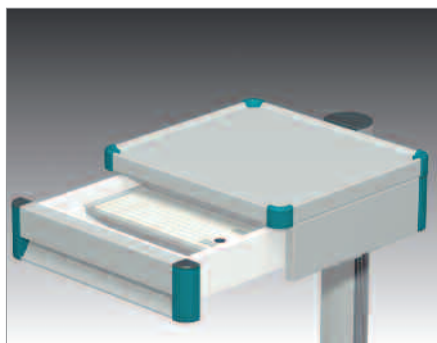
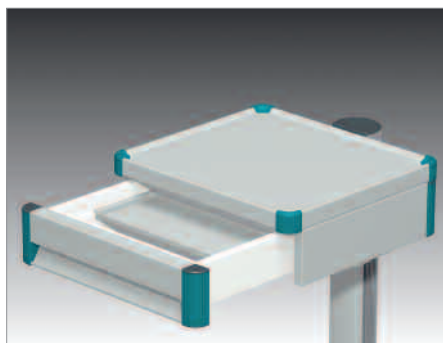

	Product line	Order number
Keyboard holder	■	RS.0261.003

¹⁾ 1 U = 32 mm

COMPUTER HOLDERS

Computer holder

The individual adaptability of this holder guarantees secure mounting for computers (tower enclosure) in widths between 50 and 225 mm and stability during transit.

- Assembly:** With an adjustable holder (left or right) on the inside of the extrusion for **classic-cart**, **compact-cart** and **endo-cart**
- Material:** Sheet steel
- Finish:** RAL 7035 Light Grey powder-coated
- Scope of delivery:** 1 computer holder with mounting hardware

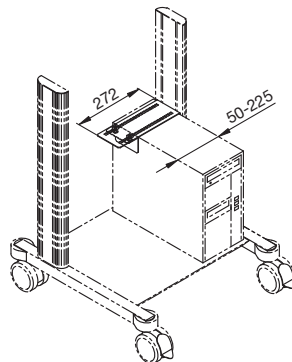

	Product line	Order number
Computer holder		GW.0709.991

Computer holder

This holder has been specially designed for small computers and two tension belts guarantee individual adaptability, secure mounting for computers and ensure stability during transit.

- Assembly:** On the support column or the inside or outside of the extrusion
- Material:** Sheet steel
- Load capacity:** 8 kg / 17.6 lbs
- Finish:** RAL 7035 Light Grey powder-coated
- Scope of delivery:** 1 computer holder for top and bottom 2 tension belts length 1000 mm with mounting hardware

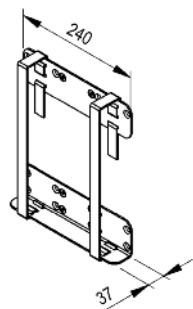

	Product line	Order number
Computer holder		TS.6144.991

uni-cart

pro-cart

classic-cart

compact-cart





endo-cart

System components
and accessories







OVERVIEW OF MONITOR HOLDERS

The same swivel and tilt unit forms the heart of the monitor holder at ITD. The monitor brackets presented in this catalogue are all mounted on this unit. All the monitor brackets have a VESA 75 / 100 adapter and a load rating between 8 kg / 17.6 lbs and maximum 14 kg / 30.8 lbs.

The following presentation gives a brief overview of the monitor holders supplied as standard and the options for attachment.

Swivel and tilt unit	Monitor bracket ¹⁾
<p>The swivel and tilt unit has the following features:</p> <ul style="list-style-type: none"> ■ It permits a tilt of $\pm 15^\circ$ and a swivel range of $\pm 158^\circ$. ■ The limit of the swivel range can be adjusted to suit individual situations. ■ The frictional force can be adjusted variably depending on the weight of the monitor. ■ The load capacity is up to a maximum of 14 kg / 30.8 lbs.  <ul style="list-style-type: none"> ■ Future-proof with easy exchange of monitor bracket – also with retrofitting. 	<div style="display: flex; align-items: center;">  <div style="margin-left: 20px;"> <ul style="list-style-type: none"> ■ VESA 75 / 100 ■ Load rating up to maximum 8 kg / 17.6 lbs </div> </div> <hr/> <div style="display: flex; align-items: center;">  <div style="margin-left: 20px;"> <ul style="list-style-type: none"> ■ VESA 75 / 100 ■ Load rating up to maximum 14 kg / 30.8 lbs </div> </div> <hr/> <div style="display: flex; align-items: center;">  <div style="margin-left: 20px;"> <ul style="list-style-type: none"> ■ VESA 75 / 100 ■ Load rating up to maximum 14 kg / 30.8 lbs ■ Depth and height adjustable </div> </div> <hr/> <div style="display: flex; align-items: center;">  <div style="margin-left: 20px;"> <ul style="list-style-type: none"> ■ The universal adapter is designed to accommodate adapter panels. ■ Load rating up to maximum 14 kg / 30.8 lbs </div> </div>

¹⁾ Manufacturer-specific monitor bracket on request

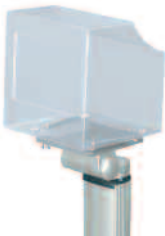
	on the support column	on the crosspiece	on the shelf
			
	Page 124	Page 124	Page 125
			
	Page 126	Page 126	Page 127
			
	Page 128	Page 128	Page 129
			
	Page 130		

MONITOR HOLDERS – UP TO 8 KG / 17.6 LBS

Monitor holder for **uni-cart** – up to 8 kg / 17.6 lbs

This monitor holder is designed with a VESA 75 / 100 adapter and attached in the support column of the product line **uni-cart**.

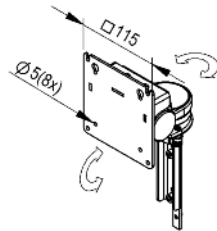

Load capacity: 8 kg / 17.6 lbs
Material: Sheet steel / Aluminium
Finish: RAL 7035 Light Grey powder-coated
Scope of delivery: 1 monitor holder, with mounting hardware

Note:

On request, the monitor holder can also be supplied with a higher load capacity.

	Product line	Order number
Monitor holder – up to 8 kg / 17.6 lbs	■	RS.0296.991

Crosspiece with monitor holder on column for **classic-cart** and **compact-cart** – up to 8 kg / 17.6 lbs

The product lines **classic-cart** and **compact-cart** also present the option of positioning the monitor holder with VESA 75 / 100 adapter on a crosspiece between the vertical extrusions.

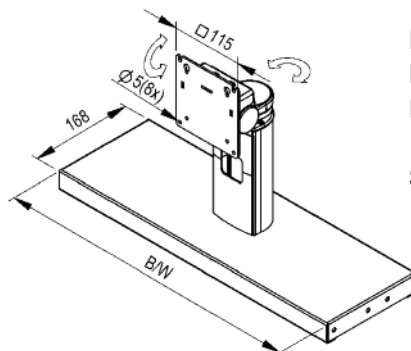
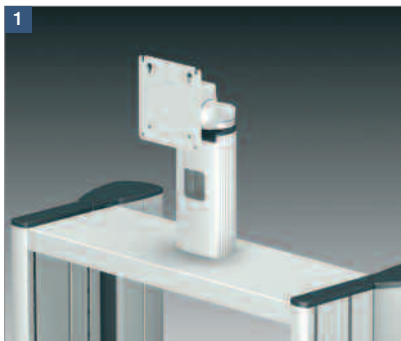

Load capacity: 8 kg / 17.6 lbs
Material: Sheet steel / Aluminium
Finish: RAL 7035 Light Grey powder-coated
Scope of delivery: 1 crosspiece with monitor holder with mounting hardware

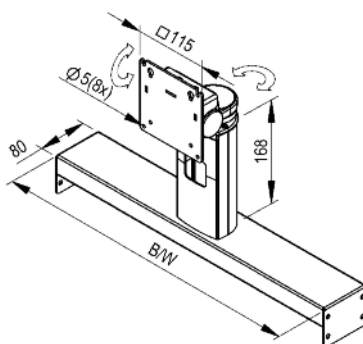
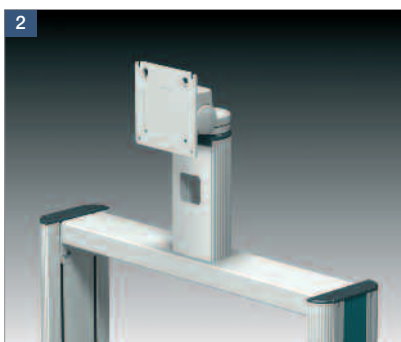

	Product line	Order number for installation width				
		W 450 mm	W 500 mm	W 600 mm	W 650 mm	
Crosspiece with monitor holder – up to 8 kg / 17.6 lbs	1	■	CC.4531.991	CC.5031.991		CC.6531.991
	2	■		GW.5024.991	GW.6024.991	

1) 1 U = 32 mm

MONITOR HOLDERS – UP TO 8 KG / 17.6 LBS

Monitor shelf (for retrofitting with monitor holder) for **classic-cart** and **compact-cart** – up to 8 kg / 17.6 lbs

This monitor shelf for the product lines **compact-cart** and **classic-cart** can be quickly retrofitted with a flat screen holder because the necessary assembly holes are already available. Small items of medical equipment can be accommodated here, saving space at the same time. The low depth facilitates access to the shelf underneath.

1 2 Monitor shelf (320 mm depth)

Platform area: 450 mm x 320 mm (W x D), for installation width 450 mm
 500 mm x 320 mm (W x D), for installation width 500 mm
 600 mm x 320 mm (W x D), for installation width 600 mm
 650 mm x 320 mm (W x D), for installation width 650 mm

Load capacity: 50 kg / 110 lbs (distributed load)

3 Monitor holder for flat screen for retrofitting, swivel and tilt

This flat screen holder has been designed for retrofitting on all the shelves listed in the ordering table. The connection dimensions for the holder have been designed for VESA 75 / 100.

Load capacity: 8 kg / 17.6 lbs

Material: Sheet steel / aluminium

Finish: RAL 7035 Light Grey powder-coated, trim elements see 1)

Scope of delivery: 1 shelf or monitor holder with mounting hardware

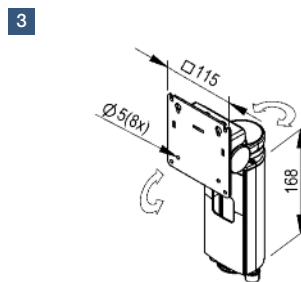
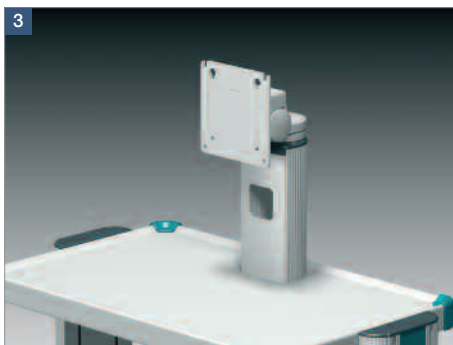
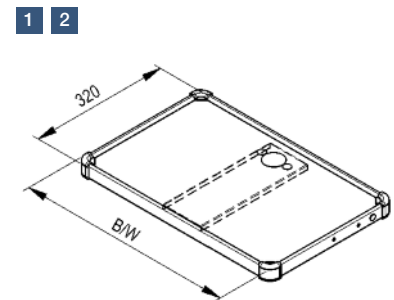
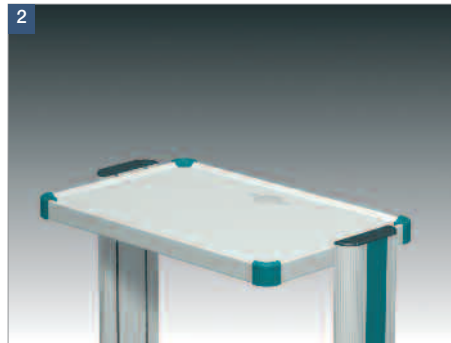
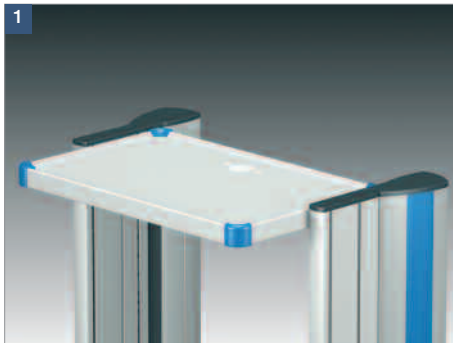

Monitor shelf for retrofitting with monitor holder	Installation height	Product line	Order number for installation width			
			W 450 mm	W 500 mm	W 600 mm	W 650 mm
1 Installation depth 320 mm	1 U ²⁾		CC.4527.XXX	CC.5027.XXX		CC.6527.XXX
2 Installation depth 320 mm	1 U ²⁾			GW.5027.XXX	GW.6027.XXX	
2 Monitor holder for retrofitting			GW.0844.991			

1) **Trim colour:** Make sure you replace in **compact-cart** .XXX by .903 = RAL 7035 Light Grey, .908 = RAL 5015 Sky Blue, .909 = RAL 1003 Signal Yellow
 Make sure you replace in **classic-cart** .XXX by .901 = RAL 5021 Water Blue, .902 = RAL 5013 Cobalt Blue, .903 = RAL 7035 Light Grey

2) 1 U = 32 mm



MONITOR HOLDERS – UP TO 14 KG / 30.8 LBS

Universal monitor holder for **pro-cart** – up to 14 kg / 30.8 lbs

The universal monitor bracket with VESA 75 / 100 adapter is used for mounting monitors up to maximum 14 kg / 30.8 lbs.

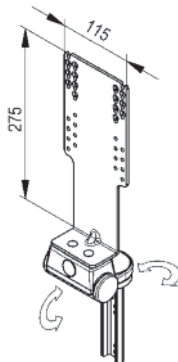

Assembly: In the front chamber of the support column
Load capacity: up to 14 kg / 30.8 lbs
Material: Sheet steel / Aluminium
Finish: RAL 7035 Light Grey powder-coated
Scope of delivery: 1 universal monitor holder with mounting hardware

	Product line	Order number
Universal monitor holder – up to 14 kg / 30.8 lbs	■	PT.4118.991

Crosspiece with universal monitor holder for **classic-cart** and **compact-cart** – up to 14 kg / 30.8 lbs

The monitor holder with VESA 75 / 100 adapter can be positioned on a crosspiece between the vertical extrusions

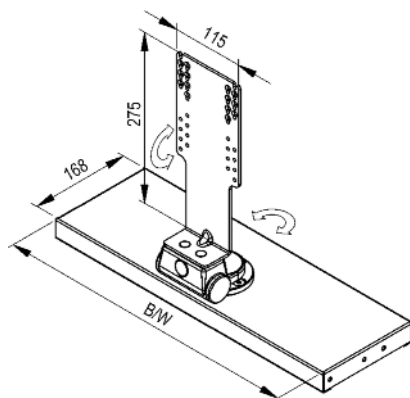
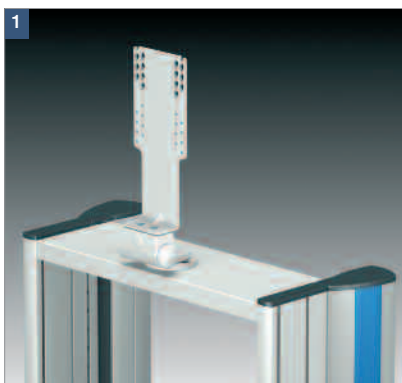

Load capacity: 14 kg / 30.8 lbs
Material: Sheet steel / Aluminium
Finish: RAL 7035 Light Grey powder-coated
Scope of delivery: 1 crosspiece with monitor holder with mounting hardware

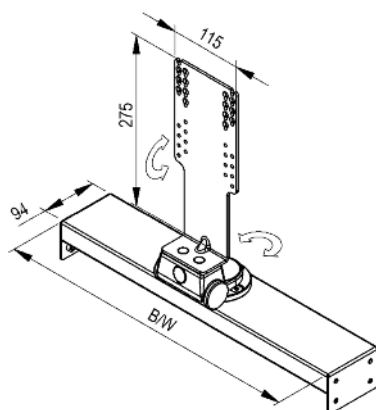

	Product line	Order number for installation width				
		W 450 mm	W 500 mm	W 600 mm	W 650 mm	
Crosspiece with monitor holder – up to 14 kg / 30.8 lbs	1	■	CC.4532.991	CC.5032.991		CC.6532.991
	2	■		GW.5096.991	GW.6096.991	

MONITOR HOLDERS – UP TO 14 KG / 30.8 LBS

Shelf D 380 mm with universal monitor bracket for **classic-cart** and **compact-cart** – up to 14 kg / 30.8 lbs

A shelf with a depth of 380 mm and a universal monitor bracket with VESA 75 / 100 adapter are supplied for the product lines **classic-cart** and **compact-cart**.

- Load capacity:** Shelf 50 kg / 110 lbs (distributed load)
 Monitor holder 14 kg / 30.8 lbs
- Material:** Aluminium / sheet steel
- Finish:** RAL 7035 Light Grey powder-coated, trim elements see 1)
- Scope of delivery:** 1 shelf with universal monitor holder, with mounting hardware

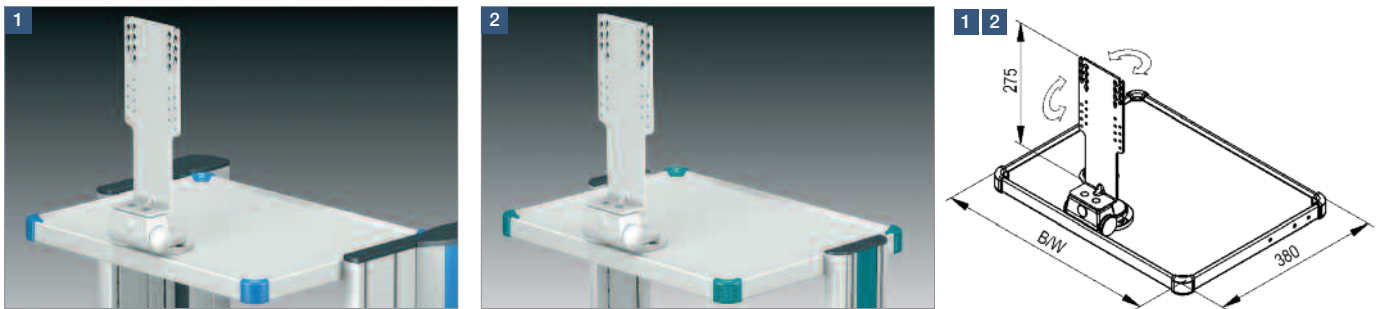

		Product line	Order number for installation width			
			W 450 mm	W 500 mm	W 600 mm	W 650 mm
Shelf D 380 mm with universal monitor holder – up to 14 kg / 30.8 lbs	1	Orange	CC.4529.XXX	CC.5029.XXX		CC.6529.XXX
	2	Green		GW.5091.XXX	GW.6091.XXX	

Twin monitor holder for **pro-cart** – each 14 kg / 30.8 lbs

The twin monitor holder with VESA 75 / 100 adaptor is suitable for **pro-cart** and has a load rating of maximum 14 kg / 30.8 lbs for each monitor holder.

- Montage:** In the front two T-slots of the support column of **pro-cart**
- Load capacity:** For each monitor holder up to max. 14 kg / 30.8 lbs
- Material:** Aluminium / steel
- Finish:** RAL 7035 Light Grey powder-coated
- Scope of delivery:** 1 stabilizer with 2 monitor holders, with mounting hardware

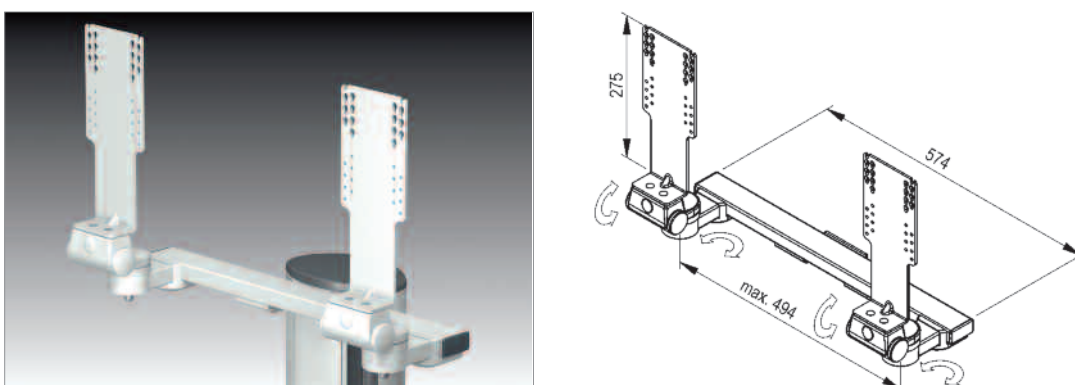

	Product line	Order number
Twin monitor holder – each 14 kg / 30.8 lbs	Green	PT.4116.991

- 1) **Trim colour:** Make sure you replace in **compact-cart** .XXX by .903 = RAL 7035 Light Grey, .908 = RAL 5015 Sky Blue, .909 = RAL 1003 Signal Yellow
- Make sure you replace in **classic-cart** .XXX by .901 = RAL 5021 Water Blue, .902 = RAL 5013 Cobalt Blue, .903 = RAL 7035 Light Grey

MONITOR HOLDERS – UP TO 14 KG / 30.8 LBS

Monitor holder for **pro-cart** – up to 14 kg / 30.8 lbs

This monitor holder is used for mounting monitors with VESA 75 / 100 adapter up to maximum 14 kg / 30.8 lbs. The three-unit division allows the depth and height of the bracket to be adjusted and adapted to different monitor sizes.

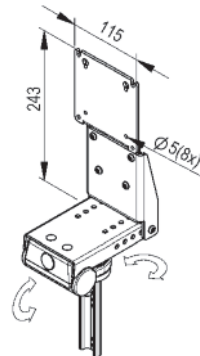

Assembly: Directly in the front chamber of the support column
Load capacity: up to 14 kg / 30.8 lbs
Material: Sheet steel / Aluminium
Finish: RAL 7035 Light Grey powder-coated
Scope of delivery: 1 monitor holder with mounting hardware

	Product line	Order number
Monitor holder – up to 14 kg / 30.8 lbs	■	PT.4119.991

Crosspiece with monitor holder for **classic-cart** and **compact-cart** – up to 14 kg / 30.8 lbs

The product lines **classic-cart** and **compact-cart** also present the option of positioning the monitor holder on a crosspiece between the vertical extrusions. The three-unit division allows the depth and height of the bracket to be adjusted.

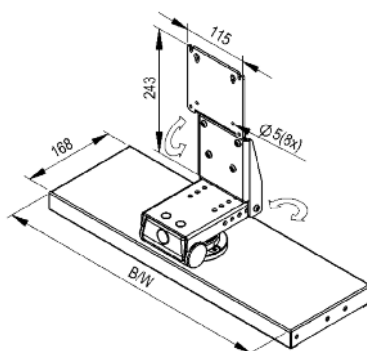
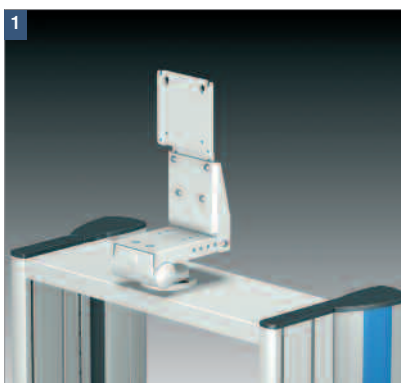

Load capacity: 14 kg / 30.8 lbs
Material: Sheet steel / Aluminium
Finish: RAL 7035 Light Grey powder-coated
Scope of delivery: 1 crosspiece with monitor holder with mounting hardware

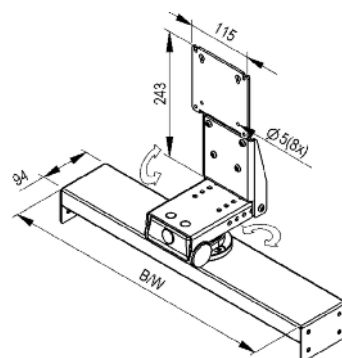

	Product line	Order number for installation width				
		W 450 mm	W 500 mm	W 600 mm	W 650 mm	
Crosspiece with monitor holder – up to 14 kg / 30.8 lbs	1	■	CC.4566.991	CC.5066.991		CC.6566.991
	2	■		GW.5097.991	GW.6097.991	

MONITOR HOLDERS – UP TO 14 KG / 30.8 LBS

Shelf D 380 mm with monitor holder for **classic-cart** and **compact-cart** – up to 14 kg / 30.8 lbs

A shelf with a depth of 380 mm and a monitor holder is supplied for the product lines **classic-cart** and **compact-cart**. The three-unit division allows the depth and height of the bracket to be adjusted.

- Load capacity:** Shelf 50 kg / 110 lbs (distributed load)
 Monitor holder 14 kg / 30.8 lbs
- Material:** Aluminium / steel
- Finish:** RAL 7035 Light Grey powder-coated, trim elements see 1)
- Scope of delivery:** 1 shelf with monitor holder, with mounting hardware

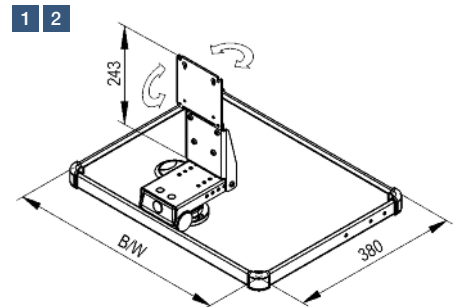
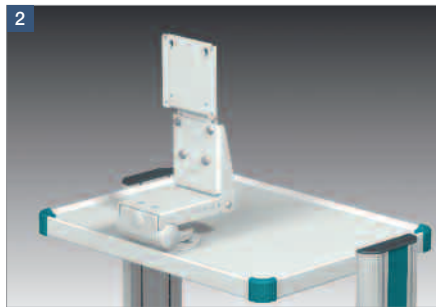
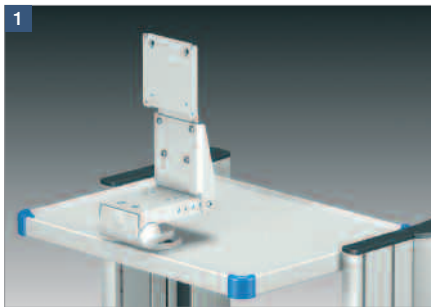

		Product line	Order number for installation width			
			W 450 mm	W 500 mm	W 600 mm	W 650 mm
Shelf D 380 mm with monitor holder – up to 14 kg / 30.8 lbs	1	Orange	CC.4565.XXX	CC.5065.XXX		CC.6565.XXX
	2	Green		GW.5092.XXX	GW.6092.XXX	

Twin monitor holder for **pro-cart** – each 14 kg / 30.8 lbs

The twin monitor holder with VESA 75 / 100 adapter is suitable for **pro-cart** and has a load rating of maximum 14 kg / 30.8 lbs for each monitor holder. The three-unit division allows the depth and height of the bracket to be adjusted.

- Assembly:** In the front two T-slots of the support column of **pro-cart**
- Load capacity:** For each monitor holder up to max. 14 kg / 30.8 lbs
- Material:** Aluminium / steel
- Finish:** RAL 7035 Light Grey powder-coated
- Scope of delivery:** 1 stabilizer with 2 monitor holders, with mounting hardware

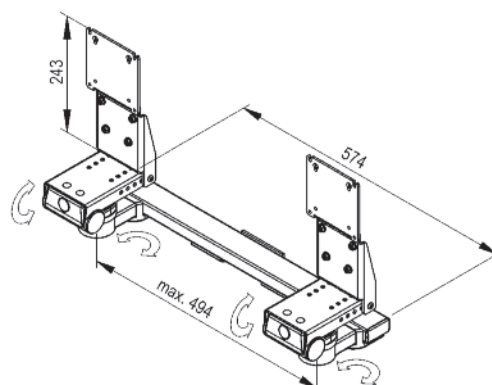
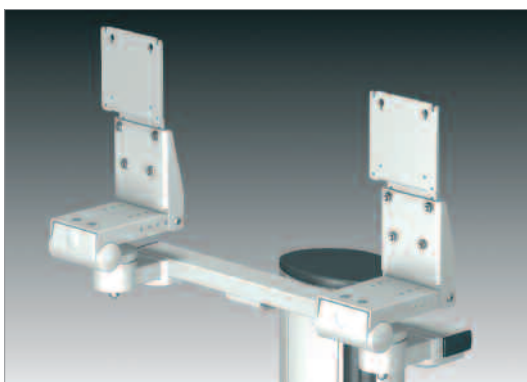

		Product line	Order number
Twin monitor holder – each 14 kg / 30.8 lbs		Green	PT.4117.991

1) **Trim colour:** Make sure you replace in **compact-cart** .XXX by .903 = RAL 7035 Light Grey, .908 = RAL 5015 Sky Blue, .909 = RAL 1003 Signal Yellow
 Make sure you replace in **classic-cart** .XXX by .901 = RAL 5021 Water Blue, .902 = RAL 5013 Cobalt Blue, .903 = RAL 7035 Light Grey

MONITOR HOLDERS – UP TO 14 KG / 30.8 LBS

Monitor / equipment holder with universal adapter for uni-cart

The monitor / equipment holder with universal adapter is designed for mounting monitor-specific adapter panels.

- Assembly:** Directly in the support column **uni-cart**
- Load capacity:** 14 kg / 30.8 lbs
- Material:** Aluminium
- Finish:** Swivel and tilt unit: RAL 7035 Light Grey powder-coated
Universal adapter: anodized
- Scope of delivery:** 1 monitor holder with universal adapter, with mounting hardware

uni-cart

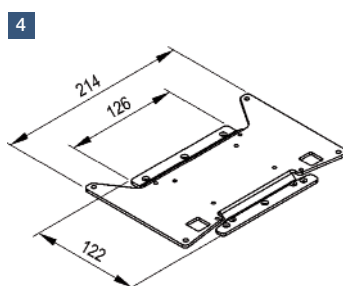
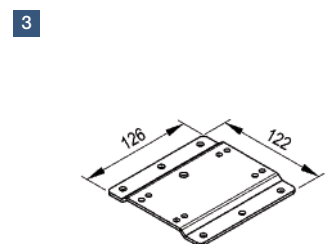
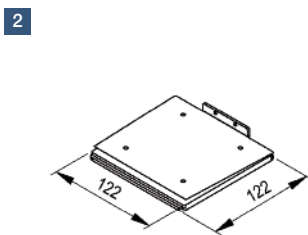
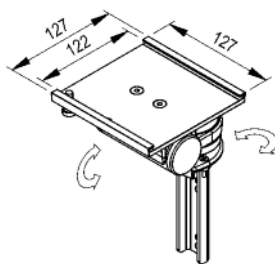

	Product line	Order number
1 Monitor / equipment holder with universal adapter	■	RS.0109.800
2 Adapter panel for Schiller Argus LCM	■	TS.0360.999
3 Adapter panel for GE Critikon Pro 100 and GE Dash 4000	■	TS.0305.999
4 Adapter panel for Nihon Kohden (Life Scope I, L und TR)	■	TS.0576.999

Other adapter panels are available on request

MONITOR HOLDERS – UP TO 10 KG / 22 LBS

Monitor holder with VESA 75 / 100, swivel and tilt

The monitor holder with VESA 75 / 100 adapter has been designed with a swivel and tilt unit for the product lines **classic-cart**, **compact-cart** and **endo-cart**. It permits a tilt of $\pm 15^\circ$ and a swivel range of 360° . The adjustment force is variable.

- Assembly:** At the side on the vertical extrusion
- Load capacity:** 10 kg / 22 lbs
- Material:** Sheet steel
- Finish:** RAL 7035 Light Grey powder-coated
- Scope of delivery:** 1 monitor holder with mounting hardware

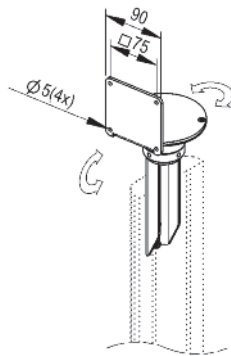

	Product line	Order number
Monitor holder with VESA 75 / 100 adapter	■ ■ ■	GW.0708.991
Adapter for VESA 100		TS.6065.991

DRAWERS

The drawers have the following features:

- Roller-guided $\frac{3}{4}$ self-retracting slides guarantee easy-slide drawers.
- The lift-out drawer unit makes cleaning easy.
- An integrated labelling strip on the front trim gives an immediate overview.
- The powder-coated finish is easy to clean and resistant to cleaning agents and disinfectants.
- The top for the drawer is always a shelf. Users derive benefit from the continuous raised edges.
- The rounded edges protect against injury and also provide an important design element for presenting the CI of the customer

Drawers for uni-cart

The block of drawers for **uni-cart** comprises the following components, depending on the design:

- 1 Shelf and drawer (including bracket)
- 2 Shelf with handle and drawer (including bracket)
- 3 Shelf with mousepad and drawer (including bracket)
- 4 Shelf with handle, mousepad and drawer (including bracket; not shown)

Assembly: In the front T-slots of the support column
Interior area: 310 mm x 260 mm x 75 mm (W x D x H)
Load capacity: Shelf: 10 kg / 22 lbs distributed load
 Drawer: 3 kg / 6.6 lbs distributed load
 Drawer with lock: 10 kg / 22 lbs distributed load
Material: Sheet steel / plastic
Finish: RAL 7035 Light Grey powder-coated, trim elements see 1)
Scope of delivery: 1 block of drawers with mounting hardware
How supplied: Pre-assembled

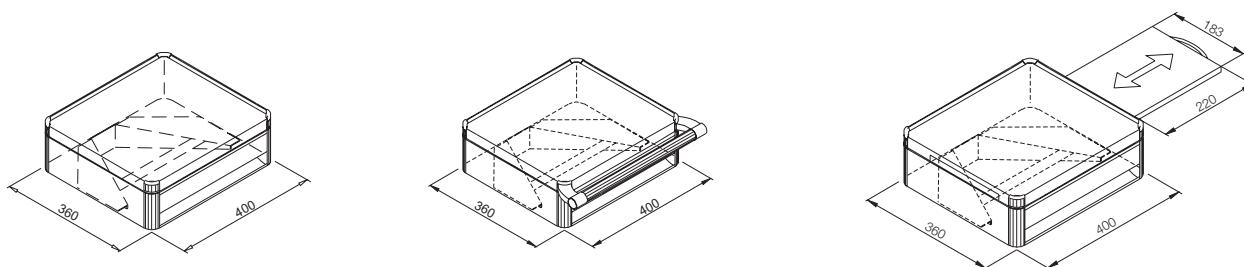

Block of drawers	Dimensions W x D (mm)	Installation height	Product line	Order number
1 Block of drawers	400 x 360	6 U ²⁾	■	RS.4363.XXX
2 Block of drawers with handle	400 x 360	6 U ²⁾	■	RS.4364.XXX
3 Block of drawers with mousepad	400 x 360	6 U ²⁾	■	RS.4369.XXX
4 Block of drawers with handle and mousepad	400 x 360	6 U ²⁾	■	RS.4368.XXX

Lock on request

1) **Trim colour:** Make sure you replace .XXX by .901 = RAL 5021 Water Blue, .902 = RAL 5013 Cobalt Blue, .903 = RAL 7035 Light Grey
 2) 1 U = 32 mm

DRAWERS

Drawers for pro-cart

The block of drawers in the product line **pro-cart** is fitted with a mechanical one-hand lock. This ensures that the drawers cannot open independently when the cart is pushed over a threshold.

The **pro-cart** block of drawers is supplied in the following versions:

- 1 Block of drawers without handle on shelf
- 2 Block of drawers with handle on shelf
- 3 Block of drawers with mousepad (right / left pullout), with and without handle on shelf
- 4 Block of drawers high, 1 unit, with and without handle on shelf

Interior area: 340 mm x 240 mm x 80 mm
(W x D x H) 340 mm x 240 mm x 175 mm (drawer high)

Load capacity: Shelf: 15 kg / 33.0 lbs distributed load
Drawer: 3 kg / 6.6 lbs distributed load

Material: Aluminium / sheet steel

Finish: RAL 7035 Light Grey powder-coated, trim elements see 1)

Scope of delivery: 1 block of drawers, with mounting hardware

How supplied: Pre-assembled

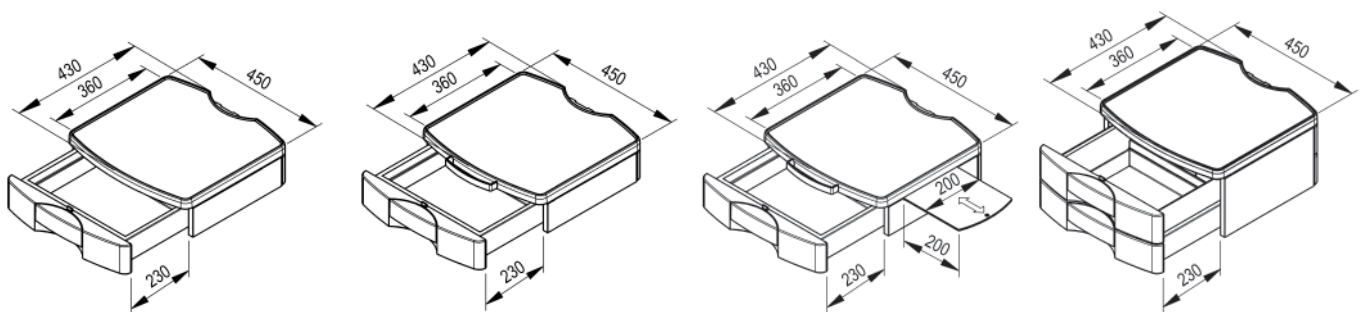
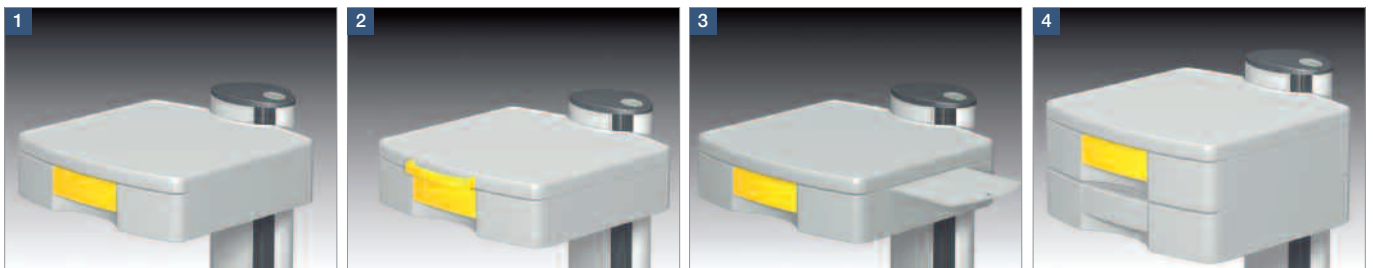

Block of drawers	Installation height	Product line	Order number
1 2 Block of drawers	1 without handle on shelf	■	PT.4104.XXX
	2 with handle on shelf	■	PT.4105.XXX
3 Block of drawers with mousepad	without handle on shelf	■	PT.4106.XXX
	with handle on shelf	■	PT.4107.XXX
4 Block of drawers high, 1 unit	without handle on shelf	■	PT.4113.XXX
	with handle on shelf	■	PT.4114.XXX

1) **Trim colour:** Make sure you replace .XXX by .903 = RAL 7035 Light Grey, .908 = RAL 5015 Sky Blue, .909 = RAL 1003 Signal Yellow

2) 1 U = 32 mm

DRAWERS

Drawers for classic-cart and endo-cart

All drawer types in the product line **classic-cart** and **endo-cart** are fitted with a latch mechanism. This ensures that the drawers cannot open independently when the cart is pushed over a threshold.

The drawer is supplied in the following versions:

- 1 Drawer
- 2 Drawer high, 1 unit

Interior area: for W 450: 360 mm x 400 mm x 85 mm
 (W x D x H) 360 mm x 400 mm x 180 mm (drawer high)
 for W 500: 410 mm x 400 mm x 85 mm
 410 mm x 400 mm x 180 mm (drawer high)
 for W 600: 510 mm x 400 mm x 85 mm
 510 mm x 400 mm x 180 mm (drawer high)

Load capacity: 3 kg / 6.6 lbs distributed load (without lock)
 20 kg / 44 lbs distributed load (with lock)

Material: Sheet steel / plastic

Finish: RAL 7035 Light Grey powder-coated, trim elements see 1)

Scope of delivery: 1 drawer or drawer high with mounting hardware

How supplied: Pre-assembled

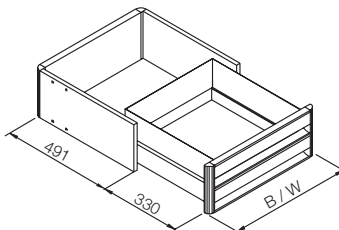
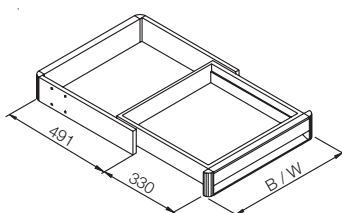
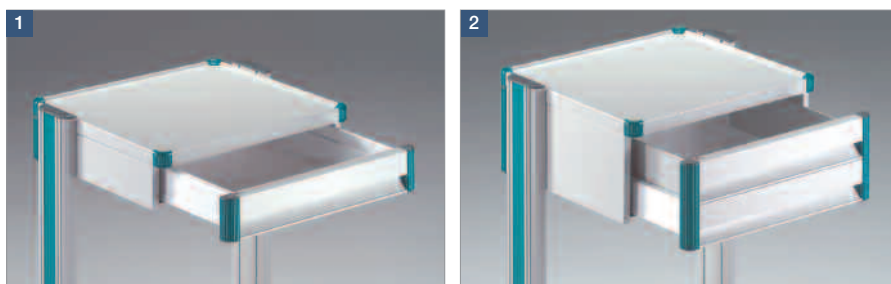

Note:

You always require a shelf of appropriate width as the top cover for the drawer (see page 114)! This is not included in the scope of delivery.

Drawers	Installation height	Product line	Order number for installation width		
			W 450 mm	W 500 mm	W 600 mm
1 Drawer	3 U ²⁾		GW.4051.XXX	GW.5051.XXX	GW.6051.XXX
2 Drawer high, 1 unit	6 U ²⁾		GW.4052.XXX	GW.5052.XXX	GW.6052.XXX

Lock on request

1) **Trim colour:** Make sure you replace .XXX by .901 = RAL 5021 Water Blue, .902 = RAL 5013 Cobalt Blue, .903 = RAL 7035 Light Grey

2) 1 U = 32 mm

Drawers for compact-cart

All drawer types in the product line **compact-cart** are fitted with a latch mechanism. This ensures that the drawers cannot open independently when the cart is pushed over a threshold.

The drawer is supplied in the following versions:

- 1 Drawer
- 2 Drawer high, 1 unit

Interior area: for W 450: 360 mm x 400 mm x 85 mm
 (W x D x H) 360 mm x 400 mm x 180 mm (drawer high)
 for W 500: 410 mm x 400 mm x 85 mm
 410 mm x 400 mm x 180 mm (drawer high)
 for W 650: 510 mm x 400 mm x 85 mm
 510 mm x 400 mm x 180 mm (drawer high)

Load capacity: 3 kg / 6.6 lbs distributed load (without lock)
 20 kg / 44 lbs distributed load (with lock)

Material: Sheet steel / plastic

Finish: RAL 7035 Light Grey powder-coated, trim elements see 1)

Scope of delivery: 1 block or drawer high with mounting hardware

How supplied: Pre-assembled

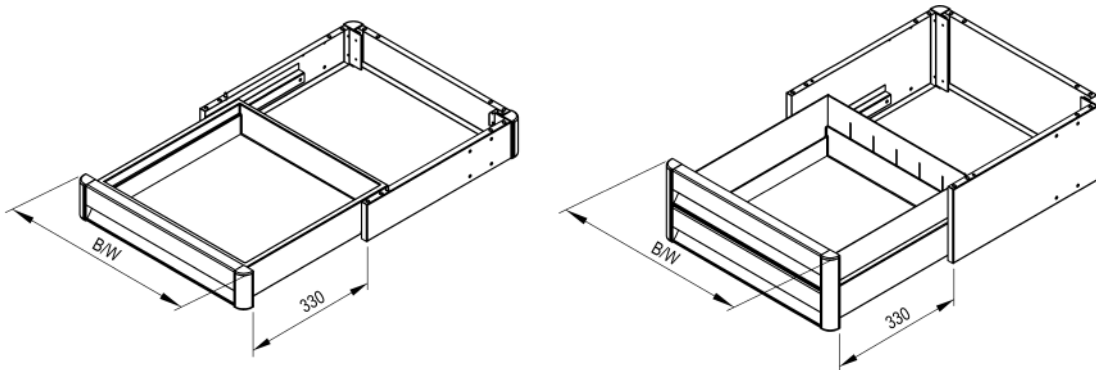
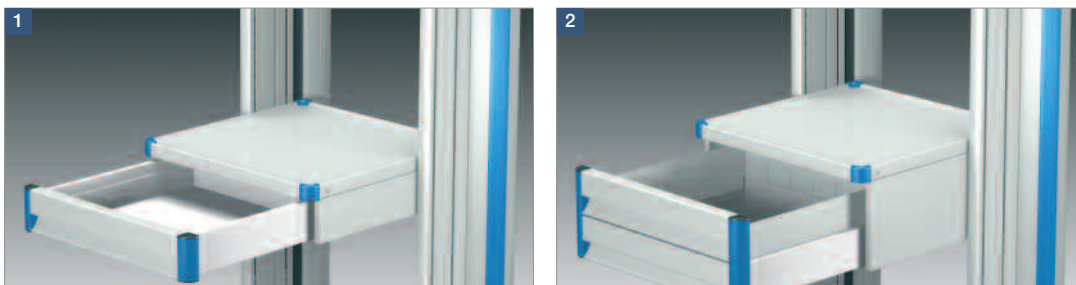

Note:

You always require a shelf of appropriate width as the top cover for the drawer (see page 115)! This is not included in the scope of delivery.

Drawer	Installation height	Product line	Order number for installation width		
			W 450 mm	W 500 mm	W 650 mm
1 Drawer	3 U ²⁾		CC.4540.XXX	CC.5040.XXX	CC.6540.XXX
2 Drawer high, 1 unit	6 U ²⁾		CC.4541.XXX	CC.5041.XXX	CC.6541.XXX

Lock on request

1) **Trim colour:** Make sure you replace .XXX by .903 = RAL 7035 Light Grey, .908 = RAL 5015 Sky Blue, .909 = RAL 1003 Signal Yellow

2) 1 U = 32 mm

BASKETS

Storage basket

The storage basket is used for storing medical accessories and is supplied in different versions:

1 Storage basket tapered for **uni-cart** und **pro-cart**

Assembly: In the front T-slots
 Mesh width: Inside dimension 18.5 mm or 23.5 mm
 Material: Steel wire
 Finish: RAL 9016 White, fluidized-bed coated

2 Storage basket tapered for **uni-cart**

Assembly: Factory assembly only, with an adaptor extrusion on the rear side of the support column
 Mesh width: Inside dimension 18.5 mm or 23.5 mm
 Material: Steel wire
 Finish: RAL 9016 White, fluidized-bed coated

Load capacity: 3 kg / 6.6 lbs distributed load

Scope of delivery: 1 basket with mounting hardware, **2** with 1 additional adapter extrusion

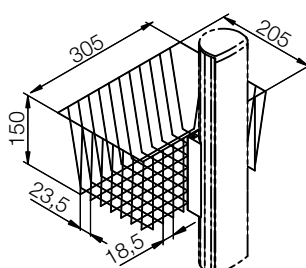
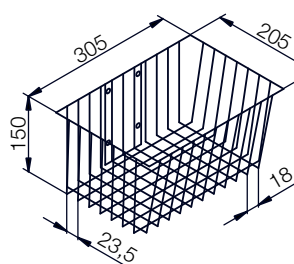
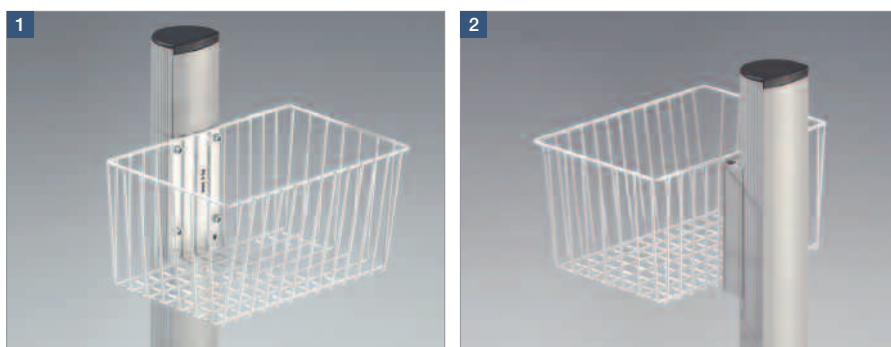

Note:

A mounting kit is necessary for attaching the storage basket **1** to the vertical extrusions of the equipment carts **classic-cart** with power column, **compact-cart** and **endo-cart**.

Storage basket	Installation height	Product line	Order number
1 Storage basket tapered	5 U ¹⁾		ZV.9967.800
2 Storage basket tapered, assembly on the rear section	5 U ¹⁾		ZV.9989.991
Mounting kit			ZV.9422.999

¹⁾ 1 U = 32 mm

Storage basket

The storage basket is used for storing medical accessories and is supplied in different versions:

1 Stainless steel basket for **uni-cart** and **pro-cart**

Assembly: In the front T-slots
 Mesh width: 8.1 mm
 Material: Stainless steel wire

2 Storage basket tapered for **uni-cart** and **pro-cart**

Assembly: In the front T-slots
 Assembly on the side sections can only be carried out in the factory.
 Mesh width: 20.5 mm
 Finish: RAL 7035 Light Grey powder-coated

Load capacity: 3 kg / 6.6 lbs distributed load

Scope of delivery: 1 basket with mounting hardware

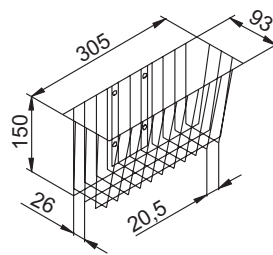
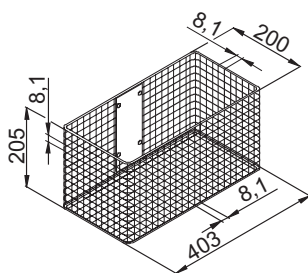
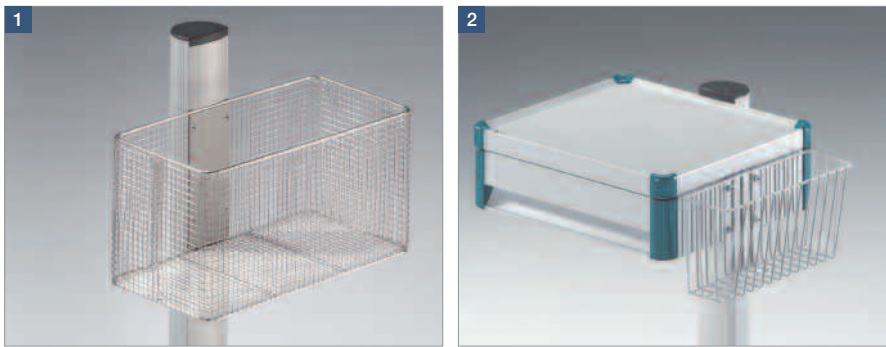

Note:

A mounting kit is necessary for attaching the storage basket to the vertical extrusions of the equipment carts **classic-cart**, **compact-cart** and **endo-cart**.

Storage basket	Installation height	Product line	Order number
1 Stainless steel basket	7 U ¹⁾		ZV.9893.999
2 Storage basket tapered	5 U ¹⁾		ZV.9892.991
Mounting kit			ZV.9422.999

¹⁾ 1 U = 32 mm

HOLDERS FOR MEDICAL ACCESSORIES

Gallery for shelf

The gallery makes transporting e.g. bottles, and/or small containers for medical consumables on the equipment cart easy. You also save valuable storage space in the drawers. The gallery is attached to a shelf and can also be used as a standard runner.

Material: Cr-Ni steel

Installation depth: 491 mm

Scope of delivery: 1 gallery with mounting hardware

How supplied: Frame pre-assembled

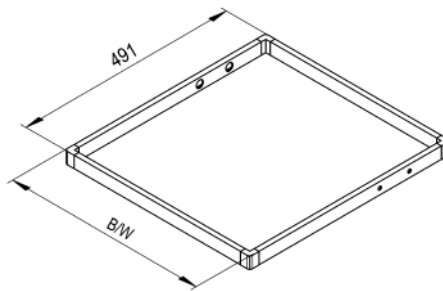
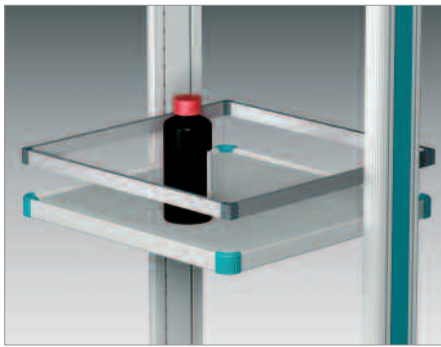

	Product line	Order number for installation width		
		W 450 mm	W 500 mm	W 600 mm
Gallery for shelf		ZV.9632.999	ZV.9633.999	ZV.9634.999

classic-cart

compact-cart

endo-cart

System components and accessories

HOLDERS FOR MEDICAL ACCESSORIES

Endoscope holders have the following features:

- They are designed to hold an endoscope (all standard brands) without introducing any kinks.
- Adjusting the height allows the holder to accommodate endoscopes up to 2 m long.
- The holder (height adjustable) provides attachment and protection.

Endoscope holder

The endoscope holder is supplied in single or dual version:

- 1 Endoscope holder **single**
Assembly: In the vertical extrusion
- 2 Endoscope holder **single**
Assembly: On two shelves or on two standard runners
- 3 Endoscope holder **single**
Assembly: In the support column of **uni-cart** and **pro-cart**
- 4 Endoscope holder **dual**
Assembly: In the vertical extrusion
- 5 Endoscope holder **dual**
Assembly: On two shelves or on two standard runners

Material: Support: polypropylene
Holder: polypropylene fibreglass reinforced
Telescopic bar: steel chrome-plated, with one-hand operation

Scope of delivery: 1 endoscope holder incl. appropriate mounting hardware



Endoscope holder	Product line	Order number
1 single – for assembly in the guide of the vertical extrusion		GW.0393.800
2 single – for assembly on the shelf / standard runner		GW.0394.991
3 single – for assembly in the support column		RS.0115.800
4 dual – for assembly in the guide of the vertical extrusions		GW.0472.800
5 dual – for assembly on the shelf / standard runner		GW.0473.991

HOLDERS FOR MEDICAL ACCESSORIES

Drain glass

The drain glass can be mounted as follows:

- 1 Using spring nuts at any height in the outer T-slot of the vertical extrusion or on the support column.
- 2 Using an attachment clamp attached directly on the telescopic bar of the endoscope holder to be height adjustable.

Content: 600 ml
Material: Drain glass made of polypropylene resistant to temperatures up to 135°C, holder made of sheet steel
Finish: Drain glass transparent milky
 Holder RAL 7035 Light Grey powder-coated
Scope of delivery: 1 Drain glass incl. appropriate fixings and mounting hardware

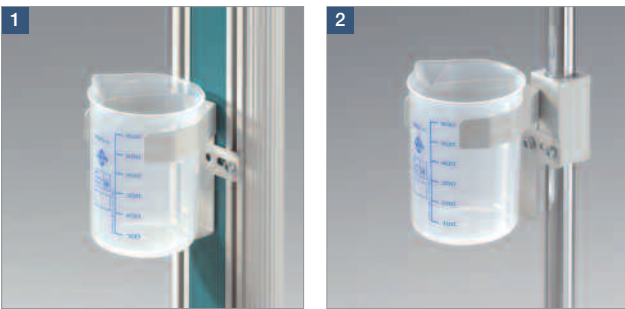

		Product line	Order number
Drain glass	1		ZV.9963.999
	2		ZV.9986.999

Connector holder

The connector holder securely accommodates up to three endoscope connectors

Assembly: On the vertical extrusion
Material: Polypropylene
Scope of delivery: 1 Connector holder with mounting hardware

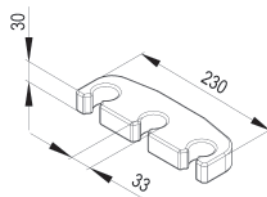

	Product line	Order number
Connector holder		ZV.9833.999

HOLDERS FOR MEDICAL ACCESSORIES

Rinsing bottle holder

An appropriate holder can be mounted at the side to accommodate a rinsing bottle.

Material: Stainless steel
Load capacity: 5 kg / 11 lbs
Scope of delivery: 1 rinsing bottle holder with mounting hardware
How supplied: Factory assembly only

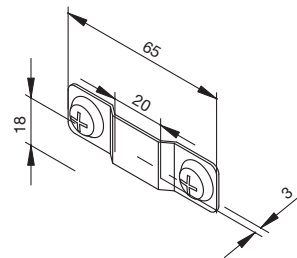
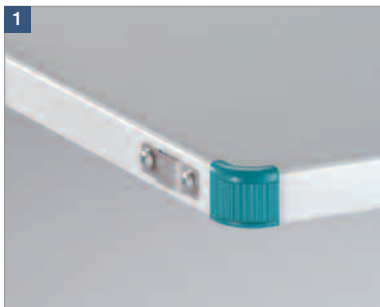

		Product line	Order number
Rinsing bottle holder	1		GW.9805.999
	2		PT.2007.100

Hose holder

The holder can accommodate hoses – e.g. from suction pumps – with a diameter of 6 mm to 14 mm.

Material: Stainless steel
Scope of delivery: 1 hose clamp with mounting hardware
How supplied: Factory assembly only

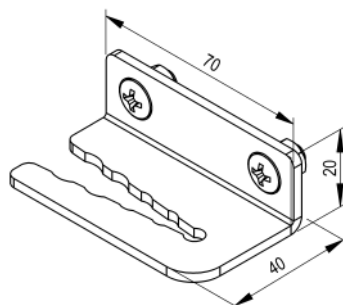
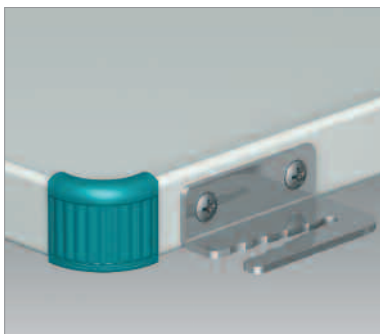

	Product line	Order number
Hose holder		GW.9882.999

uni-cart

pro-cart

classic-cart

compact-cart

endo-cart

System components
and accessories

HOLDERS FOR MEDICAL ACCESSORIES

Camera holder

The camera holder is intended for mounting the camera head (horizontal or vertical) at the eyepiece and is supplied in the following designs:

1 2 Camera holder:

- Assembly:** Underneath / at the side of the shelf
- Material:** Polyamide Black
- Scope of delivery:** 1 camera holder with mounting hardware

3 Camera holder with clamp:

- Note:** The camera holder with clamp is designed to be moved around on the shelf. The camera head is mounted vertically here. The cable hook is used to wind up the cabling.
- Material:** Camera holder: Polyamide Black;
Clamp holder: Sheet steel / aluminium, RAL 7035 Light Grey powder-coated
- Scope of delivery:** 1 camera holder with clamp holder, with mounting hardware

4 Camera holder with mounting:

- Note:** The camera holder with mounting (several options with different diameters) is ideal for camera heads and fibre-optic cables with varying diameters.
- Material:** Camera holder: Polyamide Black;
Mounting: Aluminium, RAL 7035 Light Grey powder-coated
- Scope of delivery:** 1 camera holder with mounting hardware
- How supplied:** Factory assembly only

5 Cable holder:

- Note:** The cable holder is intended for safe and reliable mounting of e.g. light guides or fibre-optic cables. The large diameter Ø 130 mm of the drum prevents any kinking in sensitive lines.
- Material:** ABS White and sheet steel RAL 7035 powder-coated
- Scope of delivery:** 1 cable holder with mounting hardware

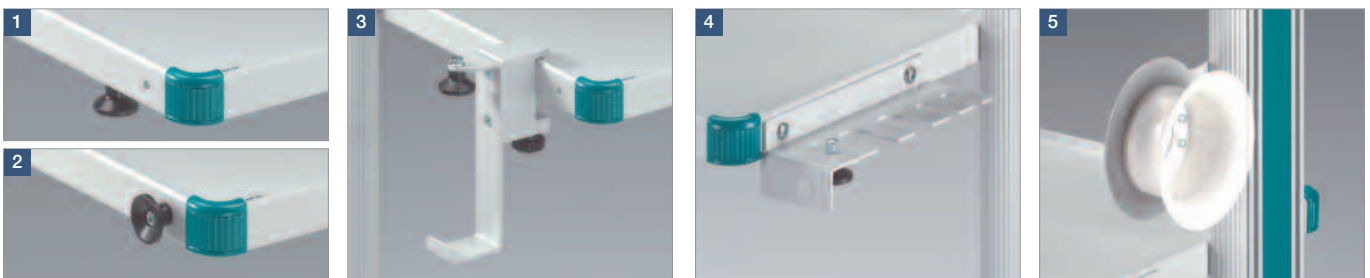

Camera holders	Product line	Order number
1 2 Camera holder		GW.9990.999
3 Camera holder with clamp		GW.9983.991
4 Camera holder with mounting		GW.9808.991
5 Cable holder		GW.9807.991

HOLDERS FOR MEDICAL ACCESSORIES

Gel bottle holder (gel bottle Ø 60 mm)

The gel bottle holder is supplied for gel bottles up to Ø 60 mm

- Assembly:** On shelf or drawer
- Material:** Sheet steel
- Finish:** RAL 7035 Light Grey powder-coated
- Scope of delivery:** 1 gel bottle holder with mounting hardware
- How supplied:** Factory assembly only

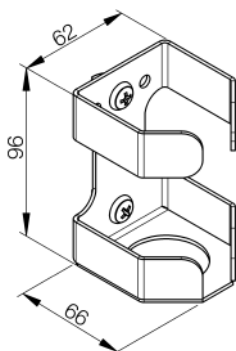

	Product line	Order number
Gel bottle holder	■ ■ ■ ■	GW.0800.991

Bottle holder

- 1** Bottle holder for holding a 1 l rinsing bottle Ø 120 mm
- 2** Bottle holder for holding a 2 l secretion glass Ø 145 mm

- Assembly:** Side mounting on the vertical extrusion of the basic frame
- Material:** Sheet steel
- Finish:** RAL 7035 Light Grey powder-coated
- Load capacity:** 5 kg / 11 lbs
- Scope of delivery:** 1 bottle holder with mounting hardware

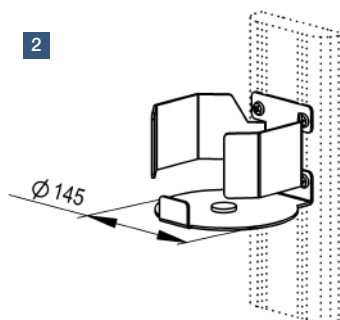
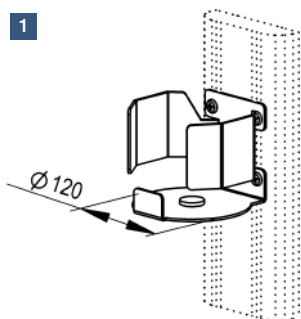

Bottle holder	Product line	Order number
1 Ø 120 mm	■ ■ ■	GW.0400.991
2 Ø 145 mm	■ ■ ■	GW.0401.991

uni-cart
pro-cart
classic-cart
compact-cart
endo-cart
System components and accessories

HOLDERS FOR MEDICAL ACCESSORIES

Gas bottle holder

The gas bottle holder can be mounted at any height or in increments of 32 mm along the vertical extrusions or the support column.

1 For gas bottles with max. 2 l content

Assembly: - At the front of the support column for **uni-cart** and **pro-cart**

- At the side on the vertical extrusion of the basic frame for **classic-cart**, **compact-cart** and **endo-cart**
- Secured with Velcro tape

2 For gas bottles with max. 2 l content

Assembly: - With adapter extrusion on the rear section of the support column for **uni-cart**

- Secured with a tension belt
- Factory assembly only

3 For gas bottles with max. Ø 145 mm, 3 l / 5 l / 10 l content

Assembly: - With adapter extrusion on the rear section of the support column for **uni-cart**

- Secured with a tension belt
- Factory assembly only

4 For gas bottles with max. Ø 145 mm, 3 l / 5 l / 10 l content

Assembly: - On the side of the vertical extrusion of the basic frame for **classic-cart**, **compact-cart** and **endo-cart**

- Secured with a tension belt

5 For gas bottles with max. Ø 205 mm, 20 l content

Assembly: - On the side of the vertical extrusion of the basic frame for **classic-cart**, **compact-cart** and **endo-cart**

- Secured with a tension belt

Load capacity: **1**, **2**, **3** 15 kg / 33 lbs
4 and **5** 38 kg / 84 lbs

Material: Sheet steel

Finish: RAL 7035 Light Grey powder-coated

Scope of delivery: 1 gas bottle holder with mounting hardware

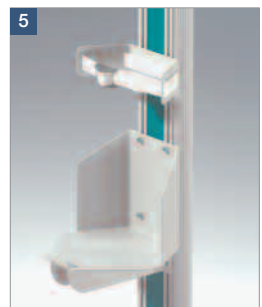

Gas bottle holder	Product line	Order number
1 for gas bottles with max. 2 l content	■ ■ ■ ■	GW.0466.991
2 for gas bottles with max. 2 l content	■	RS.0110.991
3 for gas bottles with 3 l / 5 l / 10 l content	■	RS.0111.991
4 for gas bottles with 3 l / 5 l / 10 l content	■ ■ ■	GW.0160.991
5 for gas bottles with 20 l content	■ ■ ■	GW.0285.991

HOLDERS FOR MEDICAL ACCESSORIES

Infusion stand

The infusion stand has a 4-arm safety bottle holder. The height-adjustable range is 870 mm.

- 1** Infusion stand with one-hand adjustment for **uni-cart**

Assembly: On the support column of the **uni-cart**

Load rating: 4 x 2 kg

Finish: Bright chrome-plated

Scope of delivery: 1 infusion stand, cap perforated, with mounting hardware
- 2** Infusion stand with one-hand adjustment for **pro-cart**

Assembly: On the support column of the **pro-cart**

Load rating: 4 x 2 kg

Finish: Bright chrome-plated

Scope of delivery: 1 infusion stand with mounting hardware
- 3** Infusion stand with one-hand adjustment for **classic-cart**, **compact-cart** and **endo-cart**

Assembly: By inserting it into the vertical extrusion of the basic frame

Load rating: 4 x 2 kg

Finish: Bright chrome-plated

Scope of delivery: 1 infusion stand, cap perforated, with mounting hardware
- 4** Infusion stand for **classic-cart**, **compact-cart** and **endo-cart**





Assembly: By inserting it into the vertical extrusion of the basic frames

Load rating: 4 x 5 kg

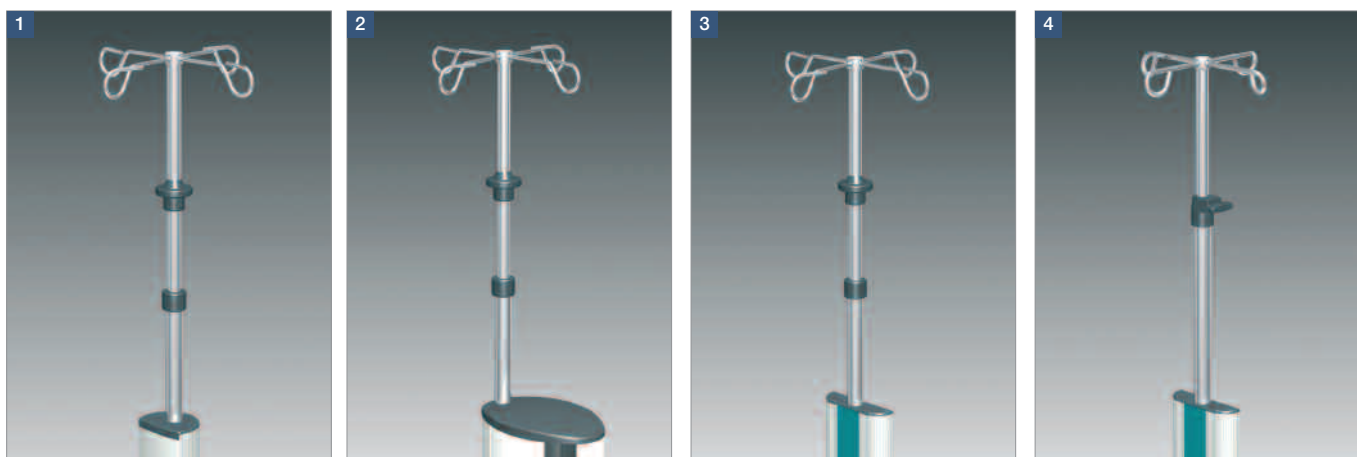
Material: Bright chrome-plated; bottle holder: Stainless steel

Scope of delivery: 1 infusion stand, cap perforated, with mounting hardware



		Number of arms	Product line	Order number
Infusion stand	1	4		ZV.9881.800
	2	4		PT.2006.999
	3	4		ZV.9882.800
	4	4		ZV.9464.800

HOLDERS FOR MEDICAL ACCESSORIES

Standard runner 10 mm x 25 mm

The standard runner can be mounted at the front of the support column or at the side of the vertical extrusion.

Load capacity: 10 kg / 22 lbs

Material: Stainless steel throughout

Scope of delivery: 1 standard runner with adapter, with mounting hardware

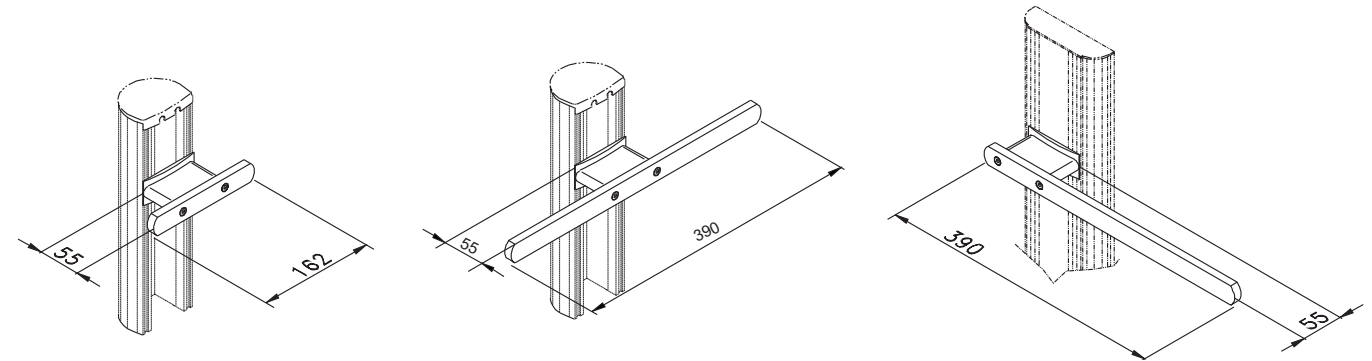
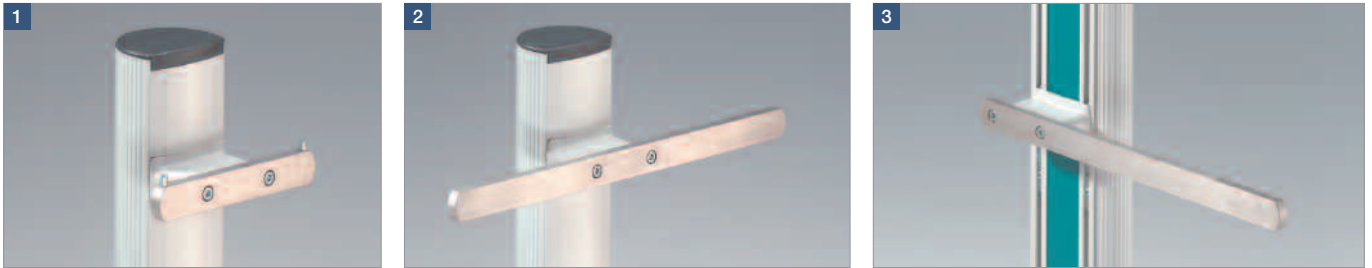

Standard runner 10 mm x 25 mm	Installation height	Product line	Order number
1 Length 162 mm	1 U ¹⁾		RS.0132.991
2 Length 390 mm	1 U ¹⁾		RS.0076.991
3 Length 390 mm	1 U ¹⁾		GW.9801.991

Anchor

The anchor is used for mounting and fastening medical equipment to standard runners.

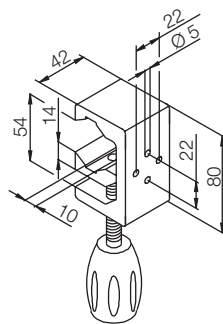

Assembly: Standard runner
Material: Aluminium
Finish: Anodized
Load capacity: 5 kg / 11 lbs
Scope of delivery: 1 anchor

Anchor	Product line	Order number
		ZV.9820.799

¹⁾ 1 U = 32 mm

HOLDERS FOR MEDICAL ACCESSORIES

Clamps

Clamps are necessary for mounting accessories with pin diameters of Ø 16 mm.

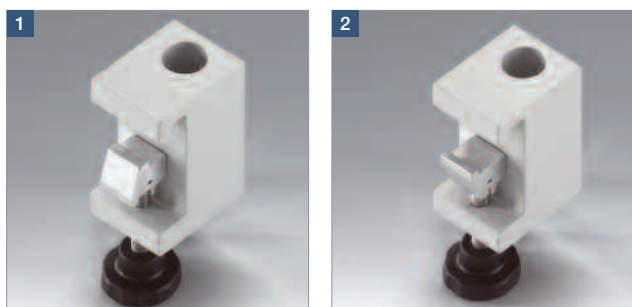

Assembly: On standard runner / shelf
Material: Aluminium
Finish: RAL 7035 Light Grey powder-coated
Scope of delivery: 1 clamp

Note:
 The clamps cannot be used in shelves with side handle.

Clamps	Mounting	Product line	Order number
1 for standard runner	Ø 16 mm		ZV.9876.999
2 for shelf	Ø 16 mm		ZV.9878.999

Rail fastener

Rail fasteners are used for mounting accessories in various positions on shelves or on standard runners.

- 1 Rail fastener Ø 25 mm is used in pairs for variable mounting of infusion stands or endoscope holders on two shelves.
- 2 Rail fastener Ø 25 mm with tapped threads is used in combination with 1 if a glass holder has to be screwed on to one of the fasteners.

Material: Aluminium
Finish: RAL 7035 Light Grey powder-coated
Scope of delivery: 1 rail fastener

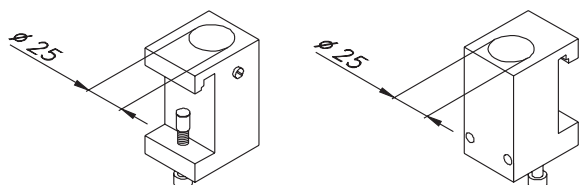
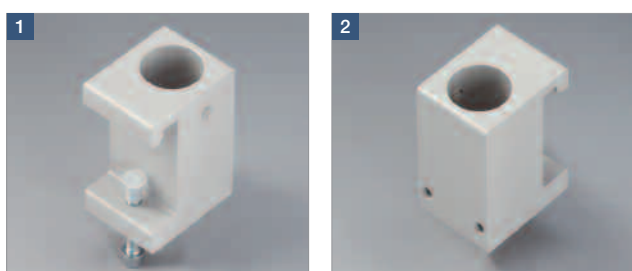

Rail fastener	Mounting	Product line	Order number
1 D 25 mm	Ø 25 mm		ZV.9957.999
2 D 25 mm for drain glass	Ø 25 mm		ZV.9958.999

HOLDERS FOR MEDICAL ACCESSORIES

Holder for suction systems

Holders for suction systems are supplied in different versions:

- 1** Holder for suction systems in the **uni-cart** support column
Assembly: Basic frame with 4 stabilizers: factory assembly only
 Basic frame with 5 stabilizers: on request
Scope of delivery: 1 holder, 2 counterweights for the basic frame, with mounting hardware
- 2** Holder for suction systems in the **pro-cart** support column
Scope of delivery: 1 holder incl. mounting hardware
- 3** Holder for suction systems for the vertical extrusion for **classic-cart, compact-cart** and **endo-cart**
Assembly: In the outer T-slots of the vertical extrusion
Scope of delivery: 1 holder incl. mounting hardware
- 4** Holder for suction systems for **classic-cart**
Assembly: In the power column
Scope of delivery: 1 holder incl. cover cap and mounting hardware

Material: Steel

Finish: RAL 7035 Light Grey powder-coated

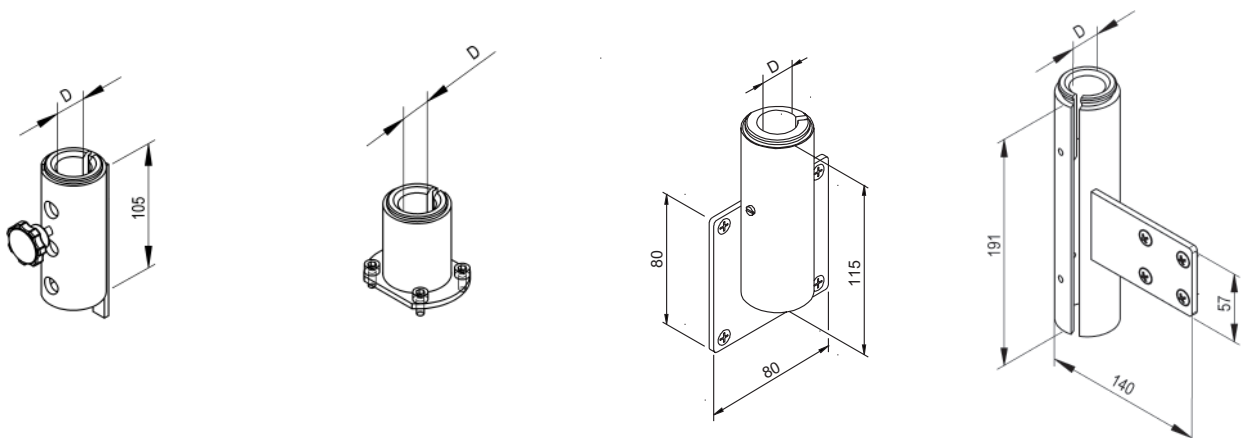
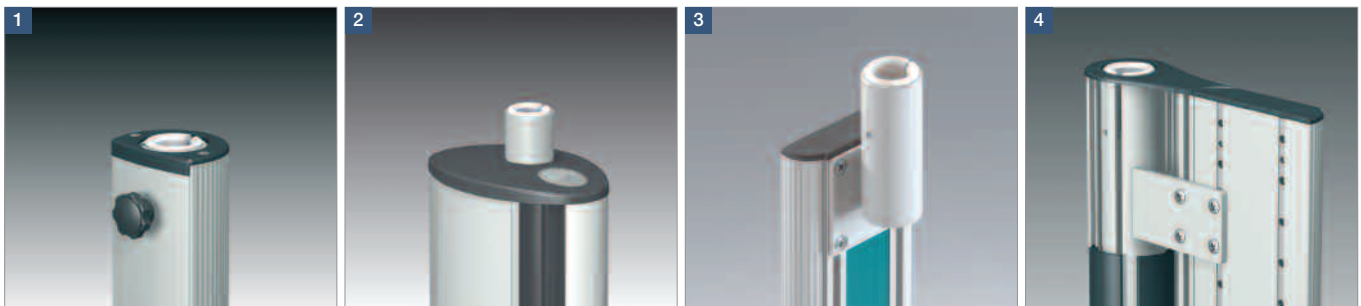

		Product line	Strässle/Ergoline Ø 25.5 mm	Order number Hellige/KISS Ø 30.0 mm	Ohlenschläger Ø 27.5 mm
Holder for suction systems	1		RS.0318.991		
	2		PT.2009.991	PT.2010.991	PT.2011.991
	3		GW.0570.991	GW.0702.991	GW.0704.991
	4		GW.0717.991		

HOLDERS FOR MEDICAL ACCESSORIES

Adapter pieces for uni-cart

Adapter pieces for **uni-cart** are supplied in the following versions:

- 1 Type 40/13: for mounting add-ons with pin diameter \varnothing 13 mm
- 2 Type 40/16: for mounting add-ons with pin diameter \varnothing 16 mm

Material: Steel zinc-plated

Scope of delivery: 1 adapter piece incl. cover cap and mounting hardware

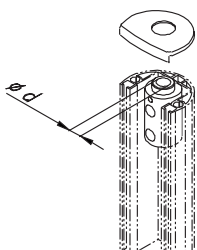

Adapter pieces	\varnothing outside	\varnothing d	Product line	Order number
1 Type 40/13	40 mm	13 mm	■	ZV.9776.999
2 Type 40/16	40 mm	16 mm	■	ZV.9830.999

Adapter pieces for classic-cart, compact-cart and endo-cart

Adapter pieces for **classic-cart**, **compact-cart** and **endo-cart** are supplied in the following versions:

- 1 Type 25/13: for mounting add-ons with pin diameter \varnothing 13 mm
- 2 Type 25/16: for mounting add-ons with pin diameter \varnothing 16 mm

Material: Stainless steel

Scope of delivery: 1 adapter piece incl. cover cap and mounting hardware

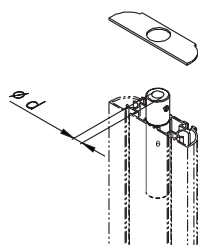

Adapter pieces	\varnothing outside	\varnothing d	Product line	Order number
1 Type 25/13	25 mm	13 mm	■ ■ ■	ZV.9901.999
2 Type 25/16	25 mm	16 mm	■ ■ ■	ZV.9952.999

HOLDERS FOR MEDICAL ACCESSORIES

Foot switch shelf

The foot switch shelf is mounted under the crosspiece of the basic frames. This allows the foot switch and cabling to be securely stored when the cart is in transit between locations.

Platform area for switch: 358 mm x 250 mm x 85 mm (W x D x H)

Material: Sheet steel

Finish: RAL 7035 Light Grey powder-coated

Scope of delivery: 1 Foot switch shelf with mounting hardware

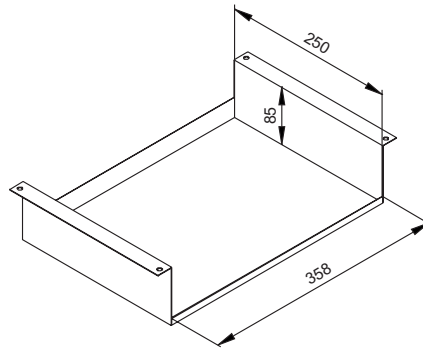

Note:

- The foot switch shelf can only be used in combination with castors Ø 125 mm (see page 111 for more detailed information on the castors)!
- Simultaneous assembly of isolating transformer and foot switch is only possible in **endo-cart**. Alternatively, the foot switch cradle (see below) can be used in this scenario.

	Product line	Order number
Foot switch shelf		ZV.9980.991

Foot switch cradle

The foot switch cradle is mounted on the vertical extrusion or on the support column.

Material: Steel

Finish: RAL 7035 Light Grey powder-coated

Scope of delivery: 1 Foot switch cradle with mounting hardware

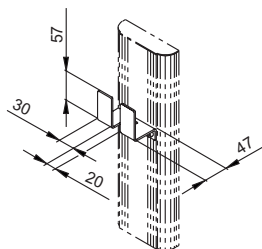
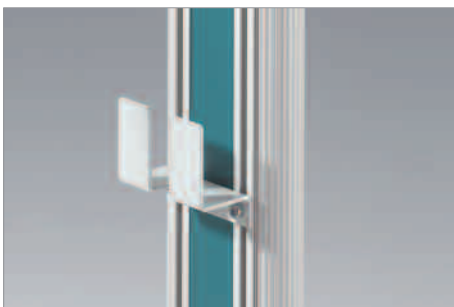

	Product line	Order number
Foot switch cradle		ZV.9991.991



HOLDERS FOR MEDICAL ACCESSORIES

Holder for transducer

This provides easy mounting for transducers.

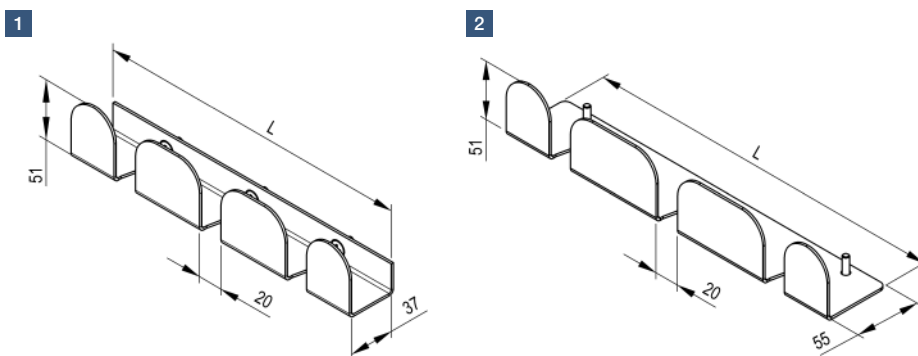
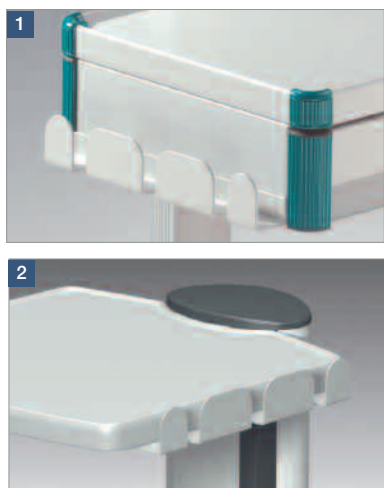
Assembly: On the shelf or drawer
Material: Sheet steel
Finish: RAL 7035 Light Grey powder-coated
Scope of delivery: 1 holder with mounting hardware
How supplied: Factory assembly only





		Length L	Product line	Order number
Holder for transducer	1	300 mm		RS.0131.991
	2	300 mm		PT.2005.991
	1	260 mm		GW.0843.991

“Dracula” box holder

The “Dracula” box holder has a spring-loaded slide to accommodate a wide range of standard commercial box sizes for tissues, wipes, disposable gloves, etc. Self-adhesive tapes provide easy mounting at the rear. Dracula can also be mounted using screws and plugs.

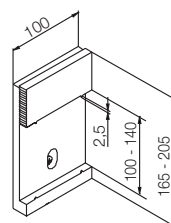
Material: Plastic White
Scope of delivery: 1 unit with mounting hardware



	Product line	Order number
“Dracula” box holder		ZV.9832.999

JOINTED ARMS

Modularity links stationary and mobile equipment carts

ITD GmbH is able to draw on the comprehensive range of jointed arms available in the **modul-port** stationary carrier system when it comes to configuring equipment carts – thanks to the 32/64 mm increments facilitating interchangeability between product lines and the resulting modularity. Mounted on the outside vertical extrusion, the jointed arms are used, e.g. to accommodate flat screens, and they allow the screens to be adjusted to an ergonomically comfortable position. A small sample of jointed arms is provided below. A complete overview is provided in the catalogue for stationary carrier systems. You can request this catalogue from the address printed on the reverse or access it on the Internet.

Pivot arm with VESA 75 / 100

This pivot arm is supplied in 1-unit and 2-unit versions and is fitted with a swivel and tilt unit including VESA 75 / 100 adapter. The arm is assembled on the support column or on vertical extrusion of the equipment cart.

- Load capacity:** 15 kg / 33 lbs
- Material:** Steel, aluminium
- Finish:** RAL 7035 Light Grey powder-coated
- Scope of delivery:** 1 pivot arm with swivel and tilt unit
incl. adapter VESA 75 / 100 and mounting hardware

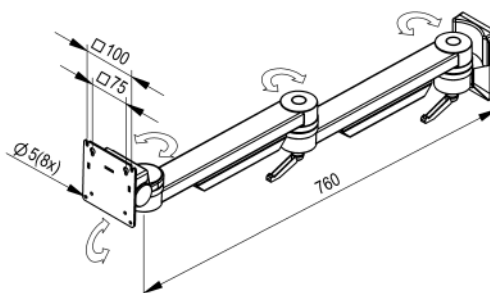
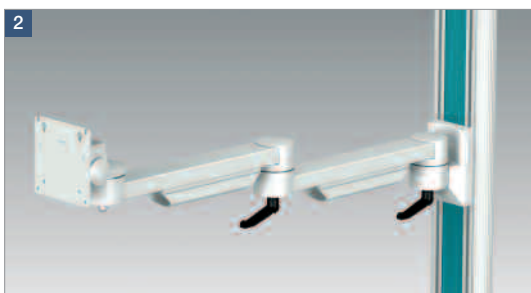
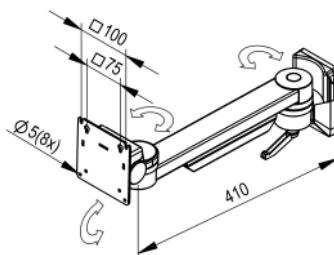
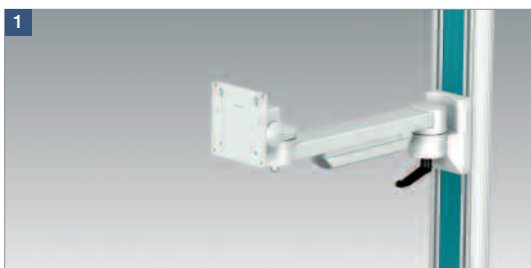

Note:

In order to guarantee maximum stability, we recommend that you check equipment carts with installed original equipment in conformity with EN60601 and order a counterweight kit as necessary.

Pivot arm	Product line	Order number
1 Pivot arm 1-unit for flat screen VESA 75 / 100		TS.6314.991
2 Pivot arm 2-unit for flat screen VESA 75 / 100		TS.6315.991

JOINTED ARMS

Variable height arm with VESA 75 / 100

Mounted at right or left on the outside vertical extrusion, the jointed arms are used e.g. for mounting a flat screen. This adjustment allows the monitor to be adjusted individually to the right position.

- 1 Variable height arm 1-unit, total length approx. 750 mm
- 2 3 Variable height arm 2-unit, total length approx. 1190 mm

Assembly: At the side on the outside of the vertical extrusion for **classic-cart**, **compact-cart** and **endo-cart**

Load capacity:

- 1 2 3-8 kg / 11-17.6 lbs alt. 6-10 kg / 13.2-22 lbs
- 1 10-13 kg / 22-28.6 lbs
- 3 8-13 kg / 17.6-28.6 lbs

Material: Steel, aluminium

Finish: RAL 7035 Light Grey powder-coated

Scope of delivery: 1 height-adjustable arm with mounting hardware

How supplied: Pre-assembled

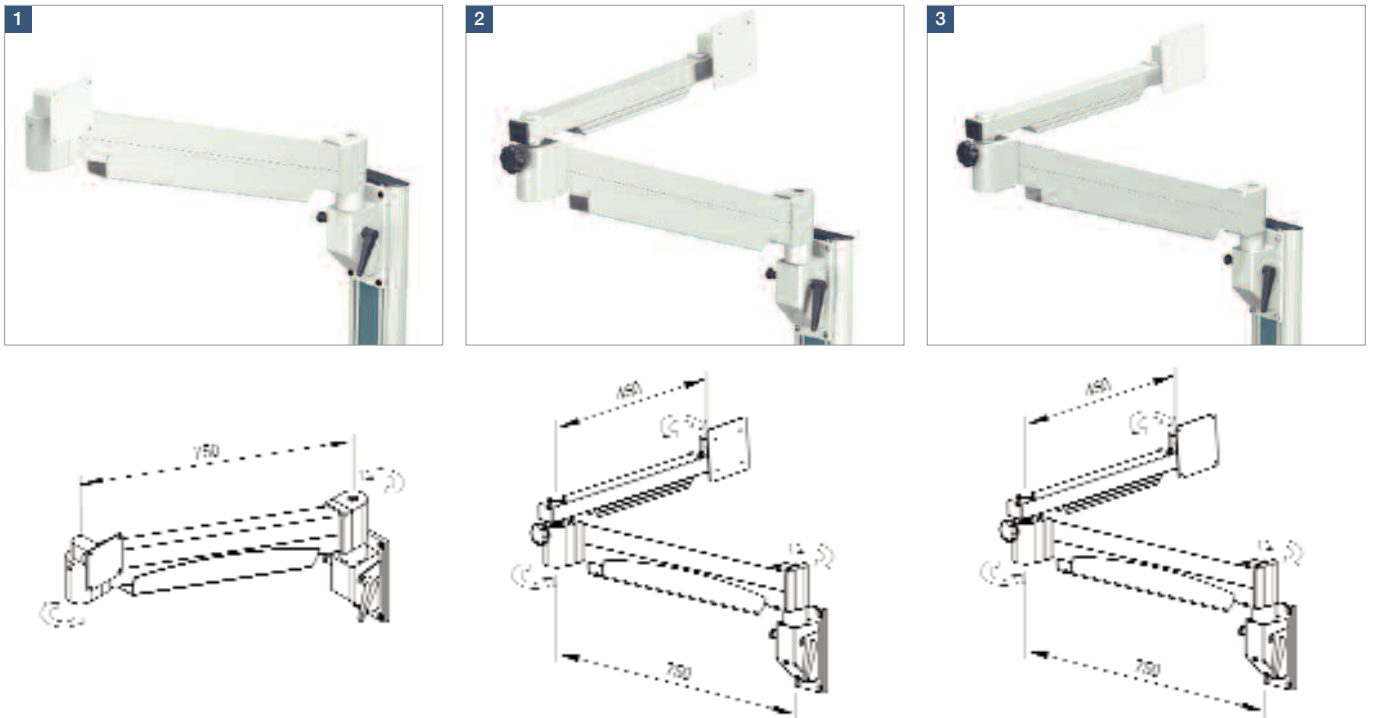

Note: When a variable height arm is mounted on the equipment carts **classic-cart** and **compact-cart** there is a risk of tilting. You should therefore order a counterweight kit (if an isolating transformer is not being installed) and check it with the equipment!

Variable height arms	VESA	Product line	Order number
1 1-unit Load capacity 3-8 kg / 6.6-17.6 lbs	75		ZV.9741.999
Load capacity 10-13 kg / 22-28.6 lbs	75		ZV.9724.999
2 2-unit Load capacity 6-10 kg / 13.2-22 lbs	75		ZV.9740.999
3 2-unit Load capacity 8-13 kg / 17.6-28.6 lbs	100		ZV.9721.999
1 counterweight kit			ZV.9511.999
1 counterweight kit			ZV.9742.999
Adapter for VESA 100			TS.6065.991

JOINTED ARMS

Handle for jointed arm

The handle for the jointed arms is suitable for all variable height arms with VESA 75. The 32.8 mm handle tube diameter means that the standard protective hood can be attached to permit sterile operations.

- Material:** Aluminium
- Finish:** RAL 7035 Light Grey powder-coated
- Scope of delivery:** 1 handle with mounting hardware

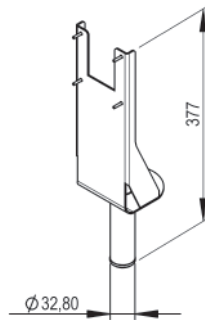
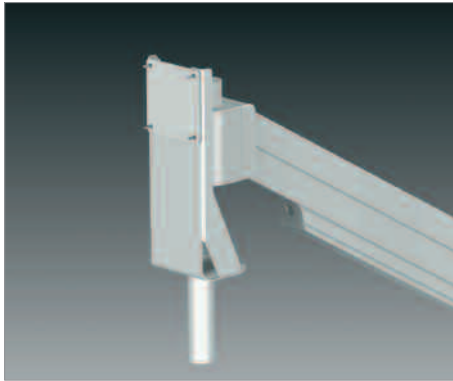

	Product line	Order number
Handle for jointed arm		GW.0776.991

Variable height arm with VESA 75 / 100, length 400 mm

This variable height arm accommodates equipment and screens which have a maximum weight in the range 15 kg. The arm is height-adjustable, can be locked out and has a length of 400 mm.

- Load capacity:** 15 kg / 33 lbs
- Material:** Steel, aluminium
- Finish:** RAL 7035 Light Grey powder-coated
- Scope of delivery:** 1 variable height arm with adapter for VESA 75 / 100 with mounting hardware

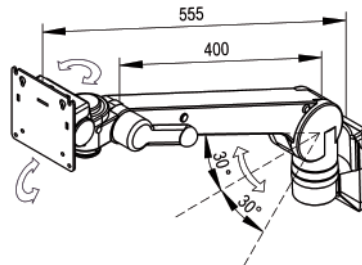

	Length	Product line	Order number
Variable height arm	400 mm		ZV.9538.999

JOINTED ARMS

Jointed arm with hose clamps

The jointed arm with hose clamps comes with a fixed and a flexible arm, e.g. for secure cable management.

Working radius:	900 mm
Mounting pins:	Ø 16 mm
Special features:	Joint clamp with knobs
Load capacity:	1 kg / 2.2 lbs
Material:	Aluminium
Finish:	Matt chrome-plated, natural anodized
Scope of delivery:	1 jointed arm with 4 hose clamps, with mounting hardware

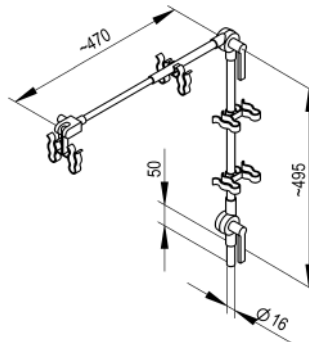

Note :

- Make sure you order an adapter piece or clamp in conformity with the method of mounting.
- You will find more detailed information on clamps on page 147.
- You will find more detailed information on adapter pieces on page 149.

	Mounting on	Product line	Order number
Jointed arm		■ ■ ■ ■ ■	ZV.9955.799
Clamp Ø 16 mm	Standard runner	■ ■ ■ ■ ■	ZV.9876.999
Clamp Ø 16 mm	Shelf	■ ■ ■ ■ ■	ZV.9878.999
Adapter piece 25/16	Vertical extrusion	■ ■ ■	ZV.9952.999
Adapter piece 40/16	Support column	■	ZV.9830.999

uni-cart

pro-cart

classic-cart

compact-cart

endo-cart

System components
and accessories

HANDLES

Handle for uni-cart

This single handle can be mounted in increments of 32 mm at any free point on the **uni-cart** support column.

- Assembly:** In the front T-slots of the support column
Material: Extruded aluminium
Finish: Bracket RAL 7035 Light Grey powder-coated, handle see trim colour ¹⁾
Scope of delivery: 1 handle with mounting hardware

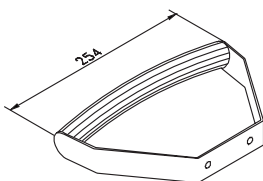

	Product line	Order number
Handle radiused	■	RS.0160.XXX

Handle for pro-cart

The push handle is mounted on the rear side of the support column and offers a push position at an angle of 90° to allow plenty of leg room for freedom of movement and a space-saving parking position at an angle of 15°.

- Material:** Cast aluminium / steel
Finish: Mount RAL 7035 Light Grey powder-coated
 Push handle powder-coated, see trim colour ¹⁾
Scope of delivery: 1 push handle with mounting hardware
How supplied: Factory assembly only

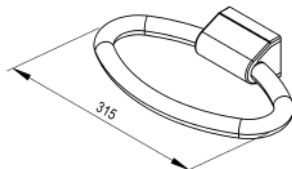
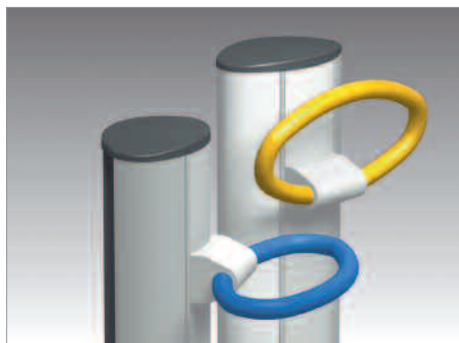

	Product line	Order number
Push handle	■	PT.2000.XXX

¹⁾ **Trim colour:** Make sure you replace in **uni-cart** .XXX by .901 = RAL 5021 Water Blue, .902 = RAL 5013 Cobalt Blue, .903 = RAL 7035 Light Grey
 Make sure you replace in **pro-cart** .XXX by .903 = RAL 7035 Light Grey, .908 = RAL 5015 Sky Blue, .909 = RAL 1003 Signal Yellow

Vertical handles for compact-cart

The following vertical handles are available for the **compact-cart** equipment cart:

1 Vertical round handle:

- Assembly:** On the outside T-slots of the vertical extrusions, variable height adjustment
- Material:** Aluminium
- Finish:** Handle brackets RAL 7035 Light Grey powder-coated; handle tube see trim colour 1)
- Scope of delivery:** 2 vertical round handles with mounting hardware
- How supplied:** Pre-assembled

2 Handle rear:

- Assembly:** On the rear side of the power columns
- Material:** Aluminium
- Finish:** RAL 7035 Light Grey powder-coated
- Scope of delivery:** 2 handles
- How supplied:** Factory assembly only

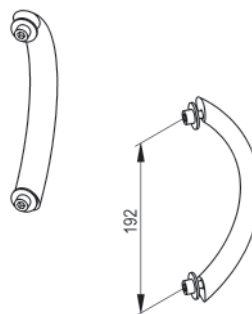
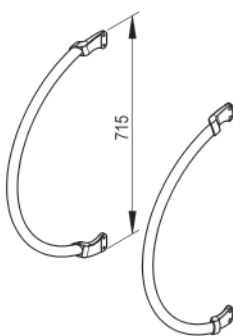
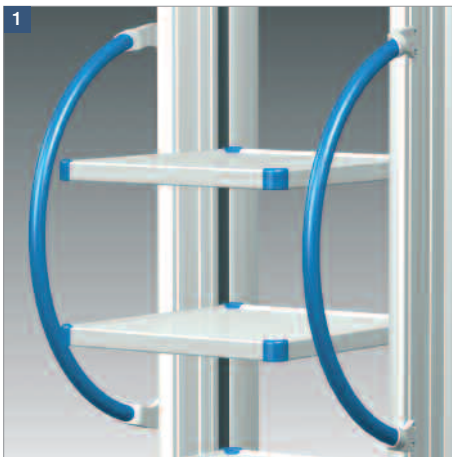

Note:

The vertical round handle under **1** cannot be combined with a shelf if a side pullout mousepad is mounted!

Vertical handles	Product line	Order number
1 Vertical handle front	■	FC.0217.XXX
2 Handle rear	■	FC.0215.991

1) **Trim colour:** Make sure you replace in .XXX by .903 = RAL 7035 Light Grey, .908 = RAL 5015 Sky Blue, .909 = RAL 1003 Signal Yellow

SOCKET STRIPS



All national and international socket strips in the product range of ITD GmbH are in conformity with the strict requirements of EN 60601 and are subject to CE marking in conformity with 93/42/EEC. They feature high quality and a robust metal housing. They can be supplied with a central on and off switch, or with and without a switch, depending on the model (see following table). They are optionally also available with plug removal barriers (see page 168). The socket strips can be integrated in the power unit (see page 167) and in the support column of equipment carts. Socket strips can also be attached to the vertical extrusion or shelf.

Note: The connecting cables of the socket strips are provided with moulded plugs. The sockets for these socket strips are also inclined at 45°, allowing right-angled plugs to be optimally positioned.

			 uni-cart
EURO socket strips	6-way	Page 160	
	6-way with central ON / OFF switch	Page 160	
Socket strip Earthed	3-way with switch ¹⁾	Page 161	ZV.9844.999
	6-way	Page 161	
	6-way with central ON / OFF switch	Page 162	
	8-way	Page 162	
	8-way with switch	Page 163	
	8-way with central ON / OFF switch	Page 163	
Socket strip French standard	6-way	Page 164	
	6-way with central ON / OFF switch	Page 164	
Socket strip Swiss standard ¹⁾	3-way with switch	Page 165	ZV.9848.999
Socket strip British standard ¹⁾	3-way with switch	Page 165	ZV.9758.999

¹⁾ Inspection in conformity with the medical equipment standard VDE0750-1 is not possible!

SOCKET STRIPS

	 pro-cart	 classic-cart	 compact-cart	 endo-cart
	ZV.9433.999	ZV.9501.999	ZV.9562.999	ZV.9501.999
	ZV.9432.999			
		ZV.9977.999		ZV.9977.999
	ZV.9435.999	ZV.9503.999	ZV.9563.999	ZV.9503.999
	ZV.9434.999			
		ZV.9504.999	ZV.9564.999	ZV.9504.999
		ZV.9502.999	ZV.9565.999	ZV.9502.999
		ZV.9505.999	ZV.9566.999	ZV.9505.999
	ZV.9441.999	ZV.9506.999	ZV.9567.999	ZV.9506.999
	ZV.9440.999			

EURO SOCKET STRIPS

EURO socket strips 6-way

Rated value: 10 A / 250 VAC

Scope of delivery: 1 socket strip with earth line and mounting hardware

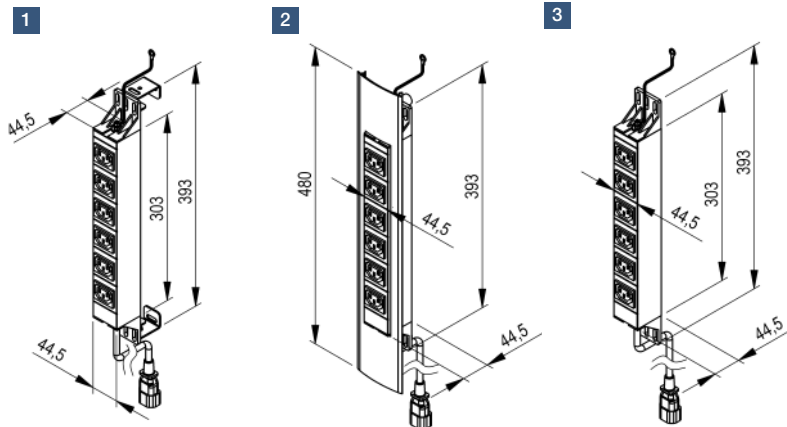

EURO socket strips 6-way	Connecting cable	Standard	Product line	Order number
1 Installation in support column pro-cart	with input plug 1)	IEC 320	■	ZV.9433.999
2 Installation in power column compact-cart	with input plug 1)	IEC 320	■	ZV.9562.999
3 Installation in power column classic-cart / endo-cart	with input plug 1)	IEC 320	■ ■	ZV.9501.999

EURO socket strips 6-way with central ON / OFF switch

Rated value: 10 A / 250 VAC

Scope of delivery: 1 socket strip with central ON / OFF switch and mounting hardware

How supplied: Factory assembly only

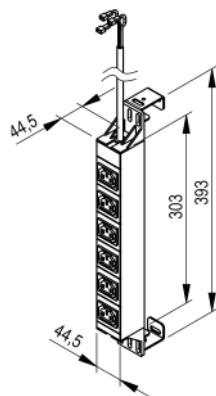

EURO socket strips 6-way with central ON / OFF switch	Connecting cable	Standard	Product line	Order number
Installation in support column pro-cart	with input plug 1)	IEC 320	■	ZV.9432.999

1) Connecting cable must be ordered separately, see page 170.

SOCKET STRIPS EARTHED

Socket strips earthed 3-way with switch

Rated value: 16 A / 250 VAC

Scope of delivery: 1 socket strip with mounting hardware

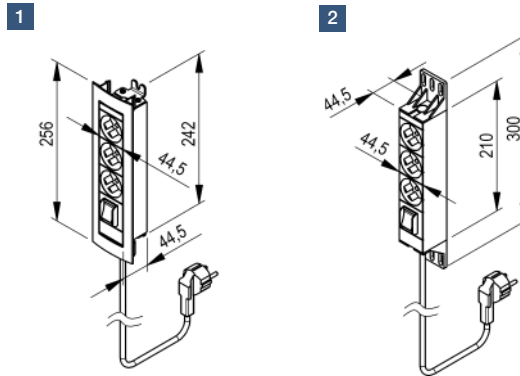

Note:

Inspection in conformity with the medical standard VDE0750-1 is not possible!

Socket strips earthed 3-way with switch	Connecting cable	Standard	Product line	Order number
1 Installation in support column uni-cart	5 m	CEE7/III		ZV.9844.999
2 Installation in power column classic-cart / endo-cart	5 m	CEE7/III		ZV.9977.999

Socket strips earthed 6-way

Rated value: 16 A / 250 VAC

Scope of delivery: 1 socket strip incl. earth line and mounting hardware

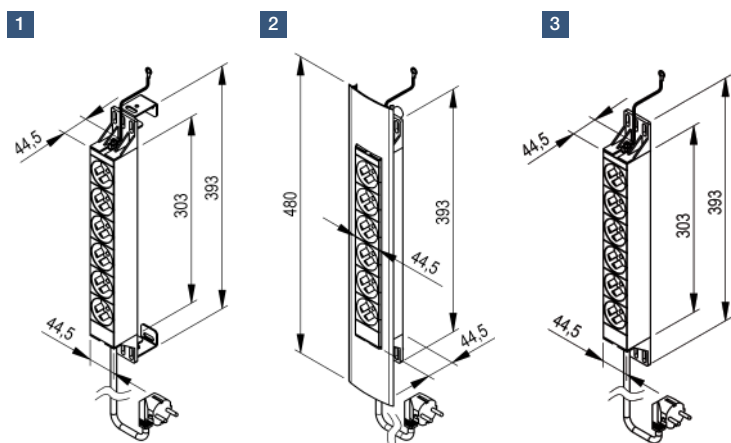

Socket strips earthed 6-way	Connecting cable	Standard	Product line	Order number
1 Installation in support column pro-cart	5 m	CEE7/III		ZV.9435.999
2 Installation in power column compact-cart	5 m	CEE7/III		ZV.9563.999
3 Installation in power column classic-cart / endo-cart	5 m	CEE7/III		ZV.9503.999

SOCKET STRIPS EARTHED

Socket strips earthed 6-way with central ON / OFF switch

Rated value: 16 A / 250 VAC

Scope of delivery: 1 socket strip with central ON / OFF switch and mounting hardware

How supplied: Factory assembly only

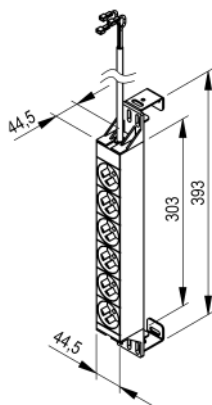

Socket strips earthed 6-way with central ON / OFF switch	Connecting cable	Standard	Product line	Order number
Installation in support column pro-cart	with input plug 1)	IEC 320	■	ZV.9434.999

Socket strips earthed 8-way

Rated value: 16 A / 250 VAC

Scope of delivery: 1 socket strip with earth line and mounting hardware

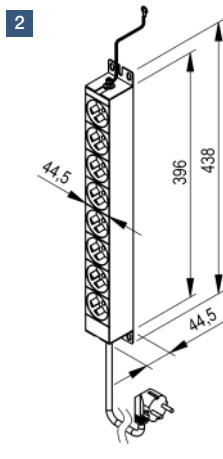
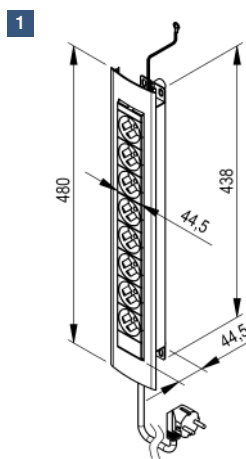

Socket strips earthed 8-way	Connecting cable	Standard	Product line	Order number
1 Installation in power column compact-cart	5 m	CEE7/III	■	ZV.9564.999
2 Installation in power column classic-cart / endo-cart	5 m	CEE7/III	■ ■	ZV.9504.999

pro-cart

compact-cart

classic-cart

endo-cart

System components and accessories

SOCKET STRIPS EARTHED

Socket strips earthed 8-way with switch

Rated value: 16 A / 250 VAC

Scope of delivery: 1 socket strip incl. earth line and mounting hardware

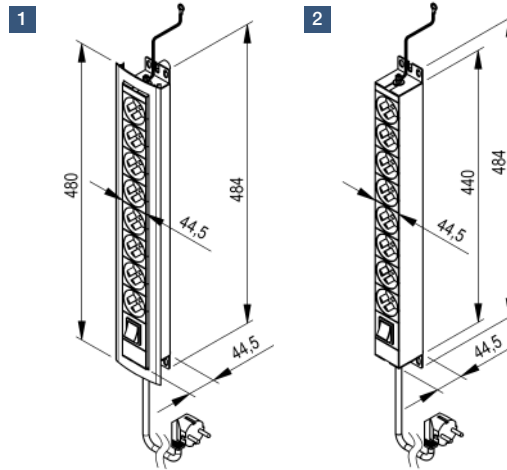

Socket strips earthed 8-way with switch	Connecting cable	Standard	Product line	Order number
1 Installation in power column compact-cart	5 m	CEE7/III		ZV.9565.999
2 Installation in power column classic-cart / endo-cart	5 m	CEE7/III		ZV.9502.999

Socket strips earthed 8-way with central ON / OFF switch

Rated value: 16 A / 250 VAC

Scope of delivery: 1 socket strip with central ON / OFF switch and mounting hardware

How supplied: Factory assembly only

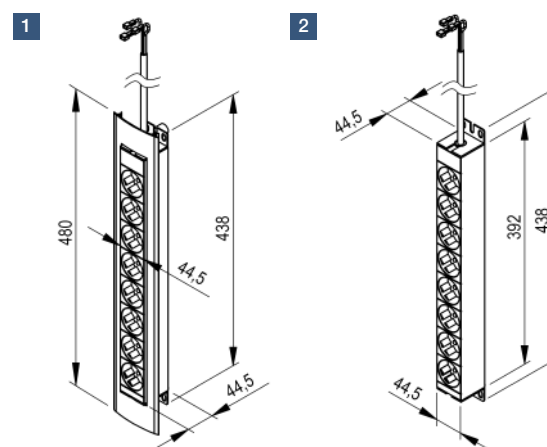

Socket strips earthed 8-way with central ON / OFF switch	Connecting cable	Standard	Product line	Order number
1 Installation in power column compact-cart	5 m	CEE7/III		ZV.9566.999
2 Installation in power column classic-cart / endo-cart	5 m	CEE7/III		ZV.9505.999

SOCKET STRIPS INTERNATIONAL

Socket strips French Standard 6-way

Rated value: 16 A / 250 VAC

Scope of delivery: 1 socket strip incl. earth line and mounting hardware

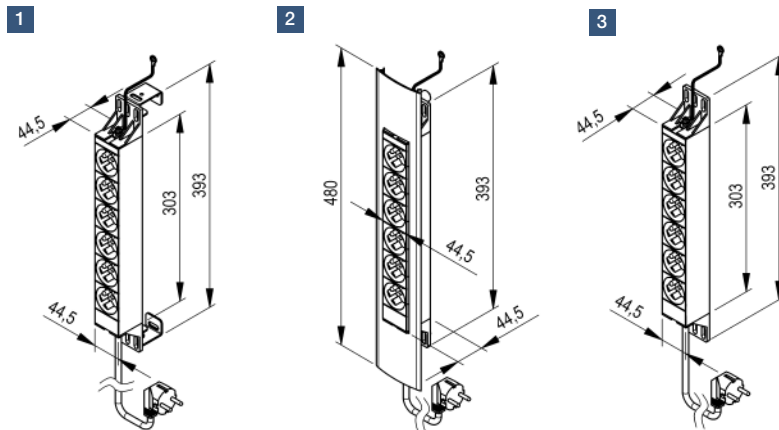

Socket strips French Standard 6-way	Connecting cable	Standard	Product line	Order number
1 Installation in support column pro-cart	5 m	CEE7, UTE		ZV.9441.999
2 Installation in power column compact-cart	5 m	CEE7, UTE		ZV.9567.999
3 Installation in power column classic-cart / endo-cart	5 m	CEE7, UTE		ZV.9506.999

Socket strips French Standard 6-way with central ON / OFF switch

Rated value: 16 A / 250 VAC

Scope of delivery: 1 socket strip with central ON / OFF switch and mounting hardware

How supplied: Factory assembly only

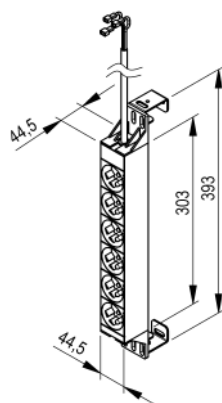

Socket strips French Standard 6-way with central ON / OFF switch	Connecting cable	Standard	Product line	Order number
Installation in support column pro-cart	5 m	CEE7, UTE		ZV.9440.999

SOCKET STRIPS INTERNATIONAL

Socket strips Swiss Standard 3-way with switch

Rated value: 13 A / 250 VAC

Scope of delivery: 1 socket strip with mounting hardware

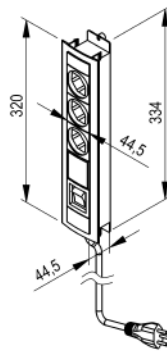

Note:

Inspection in conformity with the medical standard VDE0750-1 is not possible!

Socket strips Swiss Standard 3-way with switch	Connecting cable	Standard	Product line	Order number
Installation in support column uni-cart	2.5 m	SEV 1011	■	ZV.9848.999

Socket strips British Standard 3-way with switch

Rated value: 13 A / 250 VAC

Scope of delivery: 1 socket strip with mounting hardware

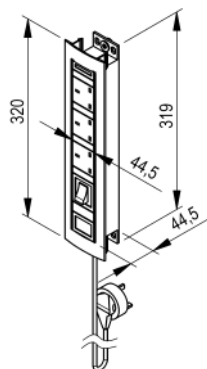

Note:

Inspection in conformity with the medical standard VDE0750-1 is not possible!

Socket strips British Standard 3-way with switch	Connecting cable	Standard	Product line	Order number
Installation in support column uni-cart	2 m	BS 1363	■	ZV.9758.999

SOCKET STRIP MOUNTING KIT

Socket strip mounting kit for **compact-cart**

Assembly: fixed to the back of the vertical extrusion of the basic frame **compact-cart** Economy
Material: Steel
Finish: RAL 7035 Light Grey powder-coated
Scope of delivery: 1 socket strip mounting kit with mounting hardware



Suitable for the following socket strips:

- EURO, 6-way (Page 160)
- Earthed, 6-way (Page 161)
- Earthed, 8-way with switch (Page 163),
- French Standard, 6-way (Page 164)

	Product line	Order number
Socket strip mounting kit	■	FC.0302.991

Socket strip mounting kit with cable winder

The socket strip mounting kit is fixed to the back of the shelf. The cable winder is designed to accommodate surplus cabling up to 5 m in length.

Finish: RAL 7035 Light Grey powder-coated
Scope of delivery: 1 socket strip mounting kit with mounting hardware



	Installation width	Suitable for socket strips	Product line	Order number
Socket strip mounting kit with cable winder	450 mm	EURO, 6-way, Earthed, 3-way, with switch, Switzerland, 3-way, with switch	■ ■ ■	GW.0681.991
	500 mm/ 600 mm/ 650 mm		■ ■ ■	GW.0631.991

POWER-UNIT

Power-Unit for **compact-cart**

compact-cart can be optionally fitted with a power unit. This combines with the power columns to provide concealed and direct cabling, accommodates sockets and the lock mechanism protects against unauthorized access.

Assembly: Between the power columns variable height assembly in increments of 32 mm

Material: Sheet steel

Finish: RAL 7035 Light Grey powder-coated

Scope of delivery: 1 power-Unit with mounting hardware

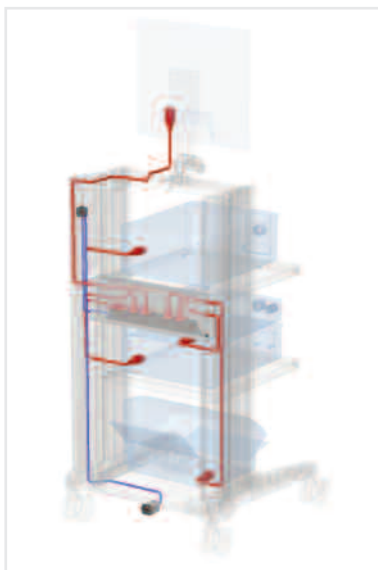
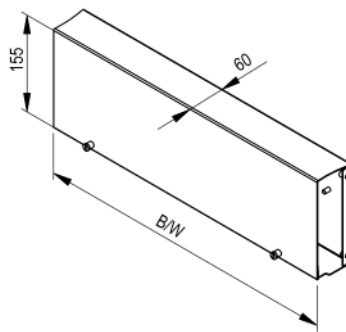

	Installation height	Product line	Order number for installation width		
			W 450 mm	W 500 mm	W 650 mm
Power-Unit for compact-cart	5 U ¹⁾		CC.4564.991	CC.5064.991	CC.6564.991

¹⁾ 1 U = 32 mm

PLUG REMOVAL BARRIER

Plug removal barrier

The plug removal barrier prevents the plugs from being inadvertently pulled out of the socket strip and avoids unauthorized equipment from being plugged in.

1 for the support column of **uni-cart**

Assembly: In front of the socket strip installed in the support column
Mounting: With four screws in the T-slots of the support column

2 for the power columns of **classic-cart** and **endo-cart**

Assembly: In front of the socket strip installed in the power column
Mounting: Inside on the vertical extrusion

3 for the power columns of **compact-cart**

Assembly: In front of the socket strip installed in the power column
Mounting: Inside on the vertical extrusion

Material: Sheet steel

Finish: RAL 7035 Light Grey powder-coated

Scope of delivery:

- 1** 1 plug removal barrier with mounting hardware
- 2** 2 brackets with mounting hardware
- 3** 1 plug removal barrier with trim, with mounting hardware



Plug removal barrier	Suitable for socket strips	Product line	Order number
1 for the support column	3-way Schuko with switch		GW.0632.991
2 for the power columns	3- / 6- / 8-way earthed		GW.0633.991
3 for the power columns	6-/8-way EURO, 6-/8-way earthed, 6-way French standard		CC.0278.991

CABLE WINDERS

Cable winder

The cable winder accommodates maximum 5 m cable.

1 Cable winder for **uni-cart**

- Assembly:** On the rear of the support column
- Finish:** Similar to RAL 7035 Light Grey
- Scope of delivery:** 2 cable winders with mounting hardware
- How supplied:** Factory assembly only

2 Cable winder for **pro-cart**

- Assembly:** On the rear of the support column
- Finish:** RAL 7035 Light Grey
- Scope of delivery:** 2 cable winders and 1 cover strip with mounting hardware

3 Cable winder for **classic-cart**, **compact-cart** and **endo-cart**

- Assembly:** On the rear panel, rear doors or at the side of the vertical extrusions
Factory assembled on the rear of the shelf or on the drawer
- Finish:** RAL 7035 Light Grey
- Scope of delivery:** 2 cable winders, supplied with mounting hardware

Material: Plastic

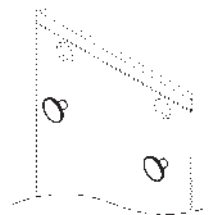
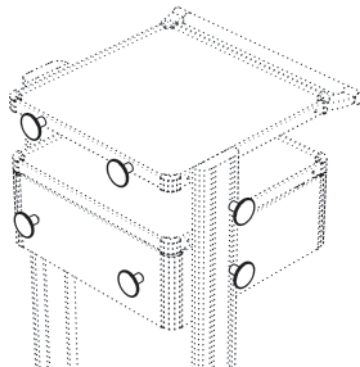
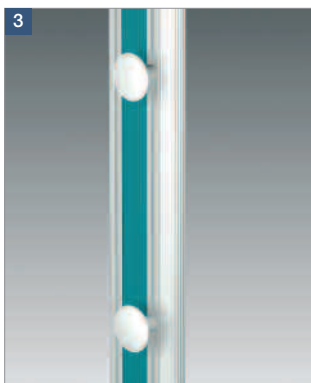
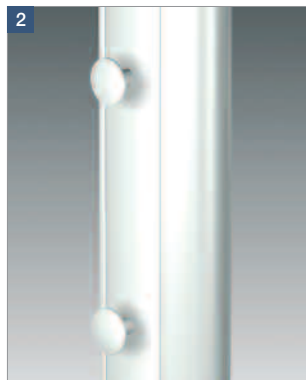
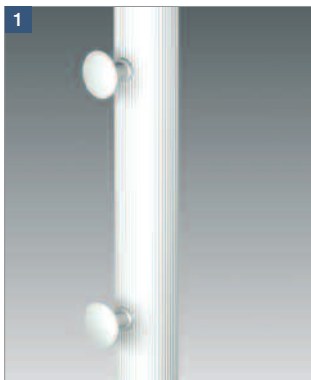

		Product line	Order number
Cable winder	1		RS.0267.991
	2		PT.2004.991
	3		FC.0253.991

uni-cart

pro-cart

classic-cart

compact-cart

endo-cart

System components
and accessories

CABLES

Power cable for EURO socket strips

A wide range of power cables are supplied for EURO socket strips with and without equipotential bonding (see page 172 for more details).

	Power plug:	EURO socket:	Rated current:	Rated voltage:	Finish:
1	CEE7 / VII	IEC 320	10 A	250 VAC	Dark Grey
2	Type 12	IEC 320	10 A	250 VAC	Dark Grey
3	Type BS 1363	IEC 320	10 A	250 VAC	Dark Grey
4	3-pole US	IEC 320	15 A	125 VAC	Black

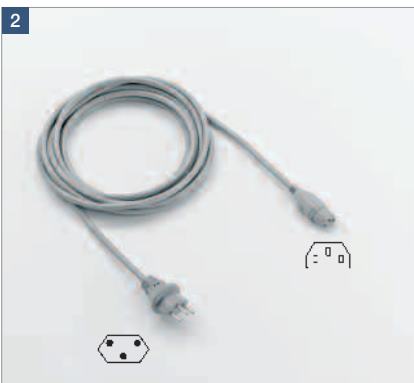

Power cable	Length	Product line	Order number	
			without equipotential bonding cable	with equipotential bonding cable
1 Earthed	5 m		ZV.9809.799	ZV.9620.999
2 Swiss Standard	5 m		ZV.9798.799	
3 British Standard	5 m		ZV.9860.799	
4 US-Standard Hospital Grade	5 m		ZV.9770.799	

EURO power cable

The EURO power cable is used to connect the EURO socket strip with the EURO plug of the unit.

Construction: IEC EURO socket→ IEC EURO plug

Finish: Dark Grey

Scope of delivery: 1 EURO power cable



	Length	Product line	Order number
EURO power cable	0.6 m		ZV.9773.799
	1.0 m		ZV.9960.799

Adapter cable

The adapter cable with fixed and assembled power cable incl. earthed plug is used to connect a unit with the EURO socket strip.

Construction: Earthed socket → EURO socket

Finish: Light Grey

Scope of delivery: 1 Adapter cable



	Length	Product line	Order number
Adapter cable	0.3 m		ZV.9959.799

EQUIPOTENTIAL BONDING

Equipotential plug S6 DIN 42801

Doctor and patient are at risk when uncontrolled currents occur. These are caused by potential differences between electrical equipment and external conductive parts in rooms used in medical settings. Installing uninterrupted potential equalization is the safest solution.

Material: Brass nickel-plated, sheet steel
Scope of delivery: 1x (4x, 6x or 8x) equipotential plug 6 DIN 42801
 1x (4x, 6x or 8x) colour marking disc yellow / green
 1 x mounting bracket with mounting hardware

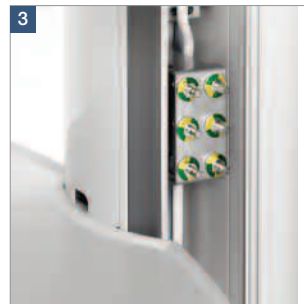

Equipotential plug S6 DIN 42801	Product line	Order number
1 Equipotential plug		ZV.9940.999
2 Panel with 8 equipotential plugs		CC.0276.999
3 Panel with 4 equipotential plugs		RS.0125.991
4 Panel with 6 equipotential plugs		PT.0197.999

Equipotential cable

The equipotential cable is used to connect installed units with the equipotential plug.



Features: Very flexible cable 6 mm² with green and yellow PVC insulation; provided with the inclined equipotential socket KBT6 DIN on both sides.
Material: Equipotential socket: brass nickel-plated
 Cable: copper
Scope of delivery: 1 cable with inclined socket on both sides

	Length	Product line	Order number
Equipotential cable	0.3 m		ZV.9941.999
	0.5 m		ZV.9942.999
	1.0 m		ZV.9943.999
	1.5 m		ZV.9488.999
	5.0 m		ZV.9944.999

ISOLATING TRANSFORMERS

Isolating transformers are used to reduce the maximum discharge current to values in conformity with rated current.

If several units are being used on one equipment cart, the individual devices are frequently supplied with electricity via one multiple socket strip mounted on the cart. The earth-leakage currents from this equipment can add up to a value that is significantly above the permissible limit of 0.5 mA. Since the earth-leakage currents can also occur during error-free operation, the isolating transformer prevents these currents from discharging to earth through the patients or the medical staff / theatre personnel. This guarantees maximum safety for all those people involved.

The isolating transformers for **pro-cart**, **classic-cart**, **compact-cart** and **endo-cart** can also be fitted with an ELG insulation monitor. This is a visual/acoustic display element that monitors falling insulation resistance in the entire system. An acoustic alert is also given if there is a hazard. This means that the medical/theatre staff can reach a timely decision on whether the procedure should be completed or whether it needs to be brought to a controlled end. It is also possible to check the overall status of the system before every examination. However, this does not replace the test/maintenance intervals laid down for individual units.

Isolating transformer for uni-cart

The isolating transformer for **uni-cart** has the following features:

Power:	660 VA
Input/output voltage:	115 V / 115 V or 230 V / 230 V, 50 Hz / 60 Hz – reversible
Power input:	IEC 320 EURO input for use of country-specific power cables
Design:	Annular core transformer in conformity with IEC 601-1 / EN 60601-1, CE marking
Conditionally short-circuit proof:	In conformity with IEC 742 and IEC 601-1
Inrush current limitation:	Electronically regulated, to approx. 15 A
Safety class:	1
Insulation voltage:	4 KV
Fuse protection:	Primary 2-phase

Scope of delivery: 1 isolating transformer with rack base and central ON / OFF switch on the right-hand side of the enclosure
 1 power cable earthed 5 metres
 3 EURO cable for connecting to the unit
 1 panel with 4x equipotential bonding plugs (assembled at the front on the **uni-cart** extrusion)

How supplied: Factory assembly only

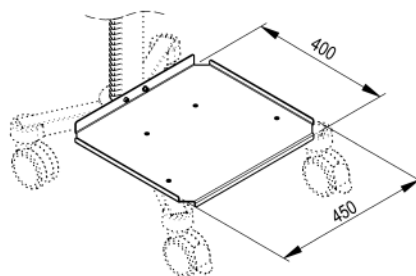

Note:

- You will find country-specific power cables on page 170.
- Please order conductive castor set, Ø 100 mm, separately if needed. (see page 111).

Isolating transformer for uni-cart	Installation height	Product line	Order number
660 VA with EURO connecting cable	3 U ¹⁾	■	ZV.9412.999

¹⁾ 1 U = 32 mm

ISOLATING TRANSFORMER

Isolating transformer for **pro-cart**

The isolating transformer for **pro-cart** has the following features:

Power:	660 VA / 1200 VA
Input/output voltage:	115 V / 115 V or 230 V / 230 V, 50 Hz / 60 Hz - reversible
Power input:	IEC 320 EURO input for use of country-specific power cables
Design:	Annular core transformer in conformity with IEC 601-1 / EN 60601-1, CE marking
Inrush current limitation:	Electronically regulated, to approx. 15 A
Safety class:	1
Insulation voltage:	4 KV
Fuse protection:	Primary: 2-phase Secondary: 1-phase at socket strip
Scope of delivery:	1 isolating transformer with basic trim 1 central on/off switch on the top of the support column 1 power cable earthed 5 m 1 EURO socket strip 4-way or 6-way IEC 320 with 4 or 6 equipotential plugs
How supplied:	Factory-assembled only

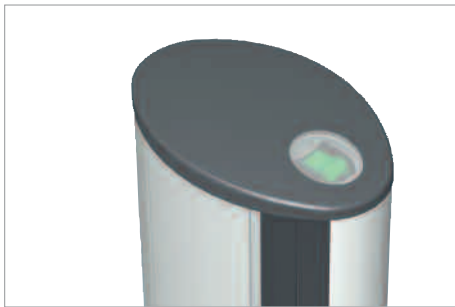
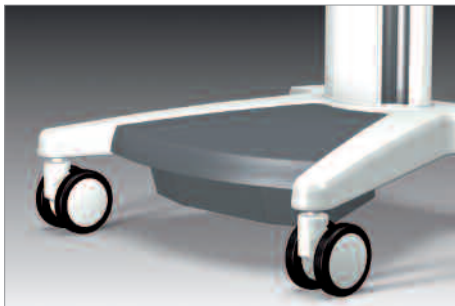

Note:

- You will find country-specific power cables on page 170
- The isolating transformer can also be supplied with an insulation monitor (see page 177)
- Please order conductive castor set, Ø 100 mm, separately if needed. (see page 111).

Isolating transformer for pro-cart	Product line	Order number
660 VA with 4-way EURO socket strip	■	ZV 9446.999
1200 VA with 6-way EURO socket strip	■	ZV 9447.999

ISOLATING TRANSFORMER

Isolating transformer for classic-cart and endo-cart

The particularly flat design of the integrated isolating transformer 660 VA, 1000 VA or 1600 VA also permits installation with the Ø 100 mm castors installed in the basic frame as standard.

Power :	660 VA / 1000 VA / 1600 VA
Input/output voltage:	115 V / 115 V or 230 V / 230 V, 50 Hz / 60 Hz - reversible
Power input:	IEC 320 EURO input for use of country-specific power cables
Design:	Annular core transformer in conformity with IEC 601-1 / EN 60601-1, CE marking
Conditionally short-circuit proof:	In conformity with IEC 742 and IEC 601-1
Inrush current limitation:	Electronically regulated, to approx. 15 A
Safety class:	1
Insulation voltage:	4 KV
Fuse protection:	Primary (2-phase) and secondary (1-phase on the socket strip)
How supplied:	Factory assembly only
Scope of delivery:	1 Isolating transformer mounted in the base, in each case with the following power:

Equipped with:	660 VA	1000 VA	1600 VA
■ Central on/off switch	Standard	Standard	Standard
■ Power cable earthed 5 metre	Standard	Standard	Standard
■ EURO socket strip each with 1x equipotential	4-way	8-way	8-way
■ Castor conversion kit conductive Ø 125 mm	Optional	Optional	Optional
■ Insulation monitor	Optional	Optional	Optional



Optional equipment with the insulation monitor ELG:

■ Operate value:	53 kOhm
■ Test resistance:	33 kOhm
■ Input voltage:	150 V / 230 V ± 15%, 50 Hz / 60 Hz
■ Alternating current internal resistance:	220 kOhm
■ Direct current internal resistance:	320 kOhm
■ Measured direct voltage:	12 V
■ Maximum measured current:	< 0,5 mA
■ Maximum permissible external direct voltage:	250 V DC

Note:

- You will find country-specific power cables on page 170.
- Please order castor set Ø 100 mm or Ø 125 mm, separately if needed (see page 111).

Isolating transformer	Product line	Order number	
		without insulation monitor	with insulation monitor
660 VA with 4-way EURO socket strip		ZV.9404.999	ZV.9405.999
1000 VA with 8-way EURO socket strip		ZV.9402.999	ZV.9403.999
1600 VA with 8-way EURO socket strip		ZV.9400.999	ZV.9401.999

ISOLATING TRANSFORMER

Isolating transformer for compact-cart

The particularly flat design of the integrated isolating transformers 1200 VA or 2000 VA also permits installation with the Ø 100 mm castors installed in the basic frame as standard.

Power:	1200 VA / 2000 VA
Input/output voltage:	1200 VA = 115 V / 115 V or 230 V / 230 V, 50 Hz / 60 Hz - reversible 2000 VA = 230 V / 230 V, 50 Hz / 60 Hz
Power input:	1200 VA / 2000 VA = IEC 320 EURO input for use of country-specific power cables
Design:	Annular core transformer in conformity with IEC 601-1 / EN 60601-1, CE marking
Conditionally short-circuit proof:	In conformity with IEC 742 and IEC 601-1
Inrush current limitation:	Electronically regulated, to approx. 15 A
Safety class:	1
Insulation voltage:	4 KV
Fuse protection:	Primary: 2-phase
How supplied:	Factory assembly only
Scope of delivery:	1 Isolating transformer mounted in the base, in each case with the following power:

Equipped with:	1200 VA	2000 VA
■ Central on/off switch	Standard	Standard
■ Power cable earthed 5 meter	Standard	Standard
■ EURO socket strip 6- or 8-way	Standard	Standard
■ Equipotential panel with 6-way or 8-way connection	6-way	8-way
■ Castor conversion kit conductive Ø 100 mm or Ø 125 mm	Optional	Optional
■ Insulation monitor	Optional	Optional



Optional equipment with the insulation monitor ELG:

■ Operate value:	53 kOhm
■ Test resistance:	33 kOhm
■ Input voltage:	150 V / 230 V ± 15% 50 Hz / 60 Hz
■ Alternating current internal resistance:	220 kOhm
■ Direct current internal resistance:	320 kOhm
■ Measured direct voltage:	12 V
■ Maximum measured current:	< 0,5 mA
■ Maximum permissible external direct voltage:	250 V DC

Note:

- You will find country-specific power cables on page 170
- Please order castor set Ø 100 mm or Ø 125 mm, separately if needed (see page 111).

Isolating transformer	Product line	Order number	
		without insulation monitor	with insulation monitor
1200 VA with 6-way EURO socket strip	■	ZV.9482.999	ZV.9483.999
2000 VA with 8-way EURO socket strip	■	ZV.9496.999	ZV.9497.999

2000 VA / 115 V version available on request

INSULATION MONITOR

Insulation monitor ELG for **pro-cart**

The functionality of the isolating transformer for **pro-cart** can also be expanded with insulation monitor ELG. This can be connected using simple Plug and Play technology. It only takes up one socket on the EURO socket strip.

This involves a visual and acoustic signal that alerts the user to falling insulation resistance in the entire system over the critical range by means of an illuminated diode. An acoustic alert is also given if there is a hazard. It is also possible to check the overall status of the system before every examination or operation. However, this does not replace the test/maintenance intervals laid down for individual units.

Supply voltage:	230 V / AC $\pm 15\%$
Operate value:	53 kOhm
Test resistance:	33 kOhm
Alternating current internal resistance:	220 kOhm
Direct current internal resistance:	320 kOhm
Max. measured voltage:	12 V
Maximum measured current:	< 0,5 mA
Maximum permissible external direct voltage:	250 V DC

Assembly:	In the front slots of the support column
Scope of delivery:	1 insulation monitor ELG 1 cover strip with mounting hardware



Note:

On request, the insulation monitor ELG is also supplied for **pro-cart** with a supply voltage of 115 V.

	Installation height	Product line	Order number
Insulation monitor ELG 230 V	7 E ¹⁾	■	PT.2008.991

MOUNTING HARDWARE

Spring nuts M6

The spring nuts are clipped into the T-slots at any point and are used for mounting system elements and accessories.

Material: Steel St 1203, Finish zinc-plated and spring band stainless steel Nirosta 4310 micro-encapsulated

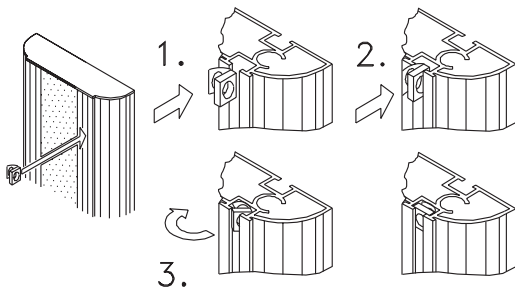

	Scope of delivery	Order number
Spring nut M6	50 Spring nuts	ZV.9851.999

Hexagon socket-head cap screws M6 x 10

■ Micro-encapsulated

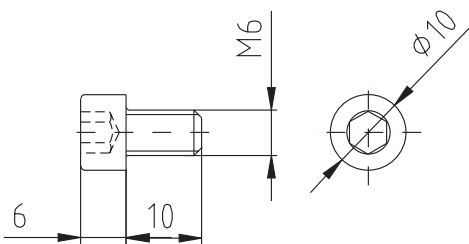

	Scope of delivery	Order number
Hexagon socket-head cap screws M6 x 10	50 Screws	ZV.9852.999

uni-cart

pro-cart

classic-cart

compact-cart

endo-cart

System components
and accessories

BESTELNUMMERNVERZEICHNIS

Bestell- nummer	Seite				
CC.0276.999	172	CC.6523.XXX	115	GW.0466.991	144
CC.0278.991	168	CC.6524.XXX	115	GW.0472.800	139
CC.4503.XXX	105	CC.6527.XXX	125	GW.0473.991	139
CC.4504.XXX	105	CC.6528.XXX	116	GW.0570.991	148
CC.4505.XXX	105	CC.6529.XXX	127	GW.0631.991	166
CC.4520.XXX	115	CC.6531.991	124	GW.0632.991	168
CC.4521.XXX	115	CC.6532.991	126	GW.0633.991	168
CC.4522.XXX	115	CC.6540.XXX	135	GW.0660.991	108
CC.4523.XXX	115	CC.6541.XXX	135	GW.0661.991	108
CC.4524.XXX	115	CC.6550.XXX	119	GW.0662.991	108
CC.4527.XXX	125	CC.6560.991	110	GW.0681.991	166
CC.4528.XXX	116	CC.6561.991	110	GW.0702.991	148
CC.4529.XXX	127	CC.6562.991	110	GW.0704.991	148
CC.4531.991	124	CC.6564.991	167	GW.0708.991	131
CC.4532.991	126	CC.6582.XXX	76	GW.0709.991	121
CC.4540.XXX	135	CC.6592.XXX	129	GW.0717.991	148
CC.4541.XXX	135	CC.6597.991	128	GW.0776.991	154
CC.4550.XXX	119	EB.4502.XXX	104	GW.0800.991	143
CC.4560.991	110	EB.4503.XXX	104	GW.0843.991	151
CC.4561.991	110	EB.4504.XXX	104	GW.0844.991	125
CC.4562.991	110	EB.4505.XXX	104	GW.4001.XXX	114
CC.4564.991	167	EB.5002.XXX	104	GW.4002.XXX	114
CC.4592.XXX	129	EB.5003.XXX	104	GW.4034.XXX	119
CC.4597.991	128	EB.5004.XXX	104	GW.4035.XXX	114
CC.5003.XXX	105	EB.5005.XXX	104	GW.4040.XXX	118
CC.5004.XXX	105	EB.6502.XXX	104	GW.4049.XXX	114
CC.5005.XXX	105	EB.6503.XXX	104	GW.4051.XXX	134
CC.5020.XXX	115	EB.6504.XXX	104	GW.4052.XXX	134
CC.5021.XXX	115	EB.6505.XXX	104	GW.4075.991	117
CC.5022.XXX	115	EC.0400.XXX	106	GW.5001.XXX	114
CC.5023.XXX	115	EC.0401.XXX	107	GW.5002.XXX	114
CC.5024.XXX	115	EC.0402.XXX	106	GW.5008.XXX	116
CC.5027.XXX	125	EC.0403.XXX	106	GW.5024.991	124
CC.5028.XXX	116	EC.0404.XXX	107	GW.5025.XXX	116
CC.5029.XXX	127	EC.0405.XXX	107	GW.5027.XXX	125
CC.5031.991	124	EC.0410.XXX	90	GW.5034.XXX	119
CC.5032.991	126	EC.0411.XXX	91	GW.5035.XXX	114
CC.5040.XXX	135	FC.0215.991	157	GW.5036.XXX	119
CC.5041.XXX	135	FC.0217.XXX	157	GW.5040.XXX	118
CC.5050.XXX	119	FC.0253.991	169	GW.5049.XXX	114
CC.5060.991	110	FC.0302.991	166	GW.5051.XXX	134
CC.5061.991	110	GW.0160.991	144	GW.5052.XXX	134
CC.5062.991	110	GW.0238.XXX	117	GW.5075.991	117
CC.5064.991	167	GW.0239.XXX	117	GW.5091.XXX	127
CC.5066.991	128	GW.0242.991	108	GW.5092.XXX	129
CC.5080.XXX	76	GW.0243.991	108	GW.5096.991	126
CC.5081.XXX	77	GW.0244.991	108	GW.5097.991	128
CC.5092.XXX	129	GW.0248.XXX	117	GW.5150.991	109
CC.5097.991	128	GW.0249.XXX	117	GW.5151.991	109
CC.6503.XXX	105	GW.0285.991	144	GW.5152.991	109
CC.6504.XXX	105	GW.0393.800	139	GW.5202.XXX	56
CC.6505.XXX	105	GW.0394.991	139	GW.5208.XXX	56
CC.6520.XXX	115	GW.0400.991	143	GW.5210.XXX	57
CC.6521.XXX	115	GW.0401.991	143	GW.5302.XXX	58
CC.6522.XXX	115			GW.5308.XXX	57
				GW.5400.XXX	58
				GW.5404.XXX	59
				GW.5406.XXX	59
				GW.5502.XXX	103
				GW.5503.XXX	103
				GW.5504.XXX	103
				GW.6001.XXX	114
				GW.6002.XXX	114
				GW.6008.XXX	116
				GW.6024.991	124
				GW.6025.XXX	116
				GW.6027.XXX	125
				GW.6034.XXX	119
				GW.6035.XXX	114
				GW.6036.XXX	119
				GW.6040.XXX	118
				GW.6049.XXX	114
				GW.6051.XXX	134
				GW.6052.XXX	134
				GW.6075.991	117
				GW.6091.XXX	127
				GW.6092.XXX	129
				GW.6096.991	126
				GW.6097.991	128
				GW.6150.991	109
				GW.6151.991	109
				GW.6152.991	109
				GW.6202.XXX	56
				GW.6208.XXX	56
				GW.6210.XXX	57
				GW.6302.XXX	58
				GW.6308.XXX	57
				GW.6400.XXX	58
				GW.6404.XXX	59
				GW.6406.XXX	59
				GW.6502.XXX	103
				GW.6503.XXX	103
				GW.6504.XXX	103
				GW.8050.991	109
				GW.8051.991	109
				GW.9801.991	146
				GW.9805.999	141
				GW.9807.991	142
				GW.9808.991	142
				GW.9882.999	141
				GW.9983.991	142
				GW.9990.999	142
				MC.1000.XXX	42
				MC.1002.XXX	43
				PT.0197.999	172
				PT.2000.XXX	156
				PT.2001.800	102
				PT.2004.991	169
				PT.2005.991	151
				PT.2006.999	145
				PT.2007.100	141
				PT.2008.991	177
				PT.2009.991	148
				PT.2010.991	148

uni-cart
 pro-cart
 classic-cart
 compact-cart
 endo-cart
 Systemkomponenten
 und Zubehör



BESTELNUMMERNVERZEICHNIS

PT.2011.991148	RS.4372.XXX112	ZV.9506.999164	ZV.9952.999155
PT.4000.991102	RS.4801.XXX18	ZV.9511.999153	ZV.9955.799155
PT.4001.991102	RS.4903.80022	ZV.9538.999154	ZV.9957.999147
PT.4002.991102	RS.5008.991101	ZV.9562.999160	ZV.9958.999147
PT.4100.991113	RS.5011.991101	ZV.9563.999161	ZV.9959.799171
PT.4101.XXX113	RS.5024.991101	ZV.9564.999162	ZV.9960.799171
PT.4102.991113			ZV.9565.999163	ZV.9963.999140
PT.4103.XXX113	TS.0305.999130	ZV.9566.999163	ZV.9964.999111
PT.4104.XXX133	TS.0360.999130	ZV.9567.999164	ZV.9967.800136
PT.4105.XXX133	TS.0361.999130	ZV.9620.999170	ZV.9977.999161
PT.4106.XXX133	TS.6065.991153	ZV.9632.999138	ZV.9980.991150
PT.4107.XXX133	TS.6144.991121	ZV.9633.999138	ZV.9986.999140
PT.4108.991120	TS.6314.991152	ZV.9634.999138	ZV.9989.991136
PT.4111.991118	TS.6315.991152	ZV.9721.999153	ZV.9991.991150
PT.4113.XXX133			ZV.9724.999153		
PT.4114.XXX133	VS.5302.XXX61	ZV.9740.999153		
PT.4116.991127	VS.5402.XXX61	ZV.9741.999153		
PT.4117.991129	VS.6402.XXX61	ZV.9742.999153		
PT.4118.991126			ZV.9758.999165		
PT.4119.991128	VT.4300.XXX39	ZV.9770.799170		
PT.5000.XXX38	VT.4301.XXX39	ZV.9773.799171		
PT.5001.XXX38	VT.4302.XXX40	ZV.9776.999149		
PT.5004.XXX40	VT.4500.XXX77	ZV.9798.799170		
PT.5006.XXX41	VT.5400.XXX60	ZV.9809.799170		
PT.5007.XXX41	VT.6400.XXX60	ZV.9820.799146		
				ZV.9830.999149		
RS.0076.991146	VW.5402.XXX60	ZV.9830.999155		
RS.0109.800130	VW.6402.XXX60	ZV.9832.999151		
RS.0110.991144			ZV.9833.999141		
RS.0111.991144	ZV.9882.800145	ZV.9844.999161		
RS.0115.800139	ZV.9400.999175	ZV.9848.999165		
RS.0125.991172	ZV.9401.999175	ZV.9851.999178		
RS.0131.991151	ZV.9402.999175	ZV.9852.999178		
RS.0132.991146	ZV.9403.999175	ZV.9860.799170		
RS.0143.991117	ZV.9404.999175	ZV.9876.999147		
RS.0160.XXX156	ZV.9405.999175	ZV.9876.999155		
RS.0261.003120	ZV.9412.999173	ZV.9878.999147		
RS.0267.991169	ZV.9422.999136	ZV.9878.999155		
RS.0296.991124	ZV.9428.999111	ZV.9881.800145		
RS.0318.991148	ZV.9432.999160	ZV.9882.800145		
RS.0344.999100	ZV.9433.999160	ZV.9892.991136		
RS.0349.999101	ZV.9434.999162	ZV.9893.999136		
RS.4008.991100	ZV.9435.999161	ZV.9901.999149		
RS.4011.991100	ZV.9440.999164	ZV.9920.999111		
RS.4027.991100	ZV.9441.999164	ZV.9921.999111		
RS.4111.XXX18	ZV.9446.999174	ZV.9922.999111		
RS.4143.XXX19	ZV.9447.999174	ZV.9922.999111		
RS.4145.XXX20	ZV.9464.800145	ZV.9923.999111		
RS.4146.XXX20	ZV.9482.999176	ZV.9924.999111		
RS.4147.XXX21	ZV.9483.999176	ZV.9926.999111		
RS.4148.XXX21	ZV.9488.999172	ZV.9927.999111		
RS.4360.XXX112	ZV.9496.999176	ZV.9929.999111		
RS.4361.XXX112	ZV.9497.999176	ZV.9940.999172		
RS.4363.XXX132	ZV.9501.999160	ZV.9941.999172		
RS.4364.XXX132	ZV.9502.999163	ZV.9942.999172		
RS.4368.XXX132	ZV.9503.999161	ZV.9943.999172		
RS.4369.XXX132	ZV.9504.999162	ZV.9944.999172		
RS.4370.XXX112	ZV.9505.999163	ZV.9952.999149		

uni-cart

pro-cart

classic-cart

compact-cart

endo-cart

Systemkomponenten
und Zubehör

STICHWORTVERZEICHNIS

A Seite

Ablageböden ausziehbar	118
Ablageböden für classic-cart und endo-cart	114
Ablageböden für compact-cart	115
Ablageböden für pro-cart	113
Ablageböden für uni-cart	112
Ablageböden seitlich mit Konsole	117
Ablageböden Tiefe 320 mm	116
Ablageböden Universal	118
Ablagekorb	136
Abtropfbecher	140
Adapterkabel	171
Adapterstücke	149

B Seite

Basisgestell classic-cart	103
Basisgestell compact-cart	104
Basisgestell endo-cart	106
Basisgestell pro-cart	102
Basisgestell uni-cart	100
Befestigungsmaterial	178
Bestellkonfigurationen classic-cart	56
Bestellkonfigurationen compact-cart	76
Bestellkonfigurationen endo-cart	90
Bestellkonfigurationen pro-cart	38
Bestellkonfigurationen uni-cart	18

C Seite

classic-cart	46
classic-cart Basisgestell	103
compact-cart	66
compact-cart Basisgestell	104

D Seite

Doppelmonitorhalterung	127
Druckerboden	116

E Seite

Edelstahlkorb	137
EKG-Wagen pro-cart	41
endo-cart	80
endo-cart Basisgestell	92
Endoskophalterung	139
Energiesäulen für classic-cart Basisgestell Profi	108

F Seite

Federmutter	178
Flaschenhalterung	143
Fußschalterablage	150
Fußschalteraufhängung	150

G Seite

Galerie für Ablageboden / Schubfach	138
Gasflaschenhalterung	144
Gelenkarm	152
Gelenkarm mit Schlauchklemmen	155
Gelflaschenhalterung	143
Gerätewagen classic-cart	46
Gerätewagen compact-cart	66
Gerätewagen endo-cart	80
Gerätewagen pro-cart	26
Gerätewagen uni-cart	8
Gerätewagen mit Höhenverstellung pro-cart	42
Gerätewagen mit Höhenverstellung uni-cart	20
Griffe	156

H Seite

Halteklau	146
Halter für Medizinisches Zubehör	138
Halter für Messwandler / Transducer	151
Halter für Sauganlagen	148
Höhenvariabler Arm für VESA Standard	153

I Seite

Infusionsstativ	145
Isolationswächter	177

K Seite

Kabel	170
Kabelaufwickelhilfe	169
Kabelhalterung	142
Kaltgeräte - Steckdosenleiste	160
Kaltgeräte	171
Kamerahalterungen	142
Klemmen	147
Klemmhalter "Dracula"	151
Körbe	136

uni-cart
 pro-cart
 classic-cart
 compact-cart
 endo-cart
 Systemkomponenten und Zubehör

STICHWORTVERZEICHNIS

L Seite

Laptop-Wagen **pro-cart**41

M Seite

Monitorboden zum Nachrüsten mit
Flachbildschirmadapter125
Monitorhalterungen124

N Seite

Netz kabel170
Normschiene146

P Seite

PC-Wagen **classic-cart**57
PC-Wagen **pro-cart**41
Potentialausgleichs-Leitung POAG172
Potentialausgleichs-Stecker POAG-S6 DIN 42801 .172
Power-Unit für compact-cart167
pro-cart26
pro-cart Basisgestell102

R Seite

Rackboden117
Rechnerhalter121
Rollenumbausatz111
Rollstand **uni-cart**22
Rücktüren für **compact-cart** Basisgestell Profi ...110
Rückwand für **classic-cart**109
Rückwand für **endo-cart**109

S Seite

safety-cart57
Schienenbefestigung147
Schlauchhalterung141
Schubfächer für **uni-cart**132
Schubfächer für **classic-cart** und **endo-cart**134
Schubfächer für **compact-cart**135
Schubfächer für **pro-cart**133
Schwenkarm für VESA Standard152
Seitlicher Ablageboden mit Konsole117
Spülflaschenhalterung141

Steckdosenleiste Kaltgeräte160
Steckdosenleiste Schuko161
Steckdosenleisten Britischer Standard165
Steckdosenleisten Französischer Standard164
Steckdosenleisten Schweizer Standard165
Steckdosenleistenbefestigung166
Steckerauszugssperre168
Steckerhalterung140

T Seite

Tastaturauszug mit / ohne Mousepad119
Tastaturhalterung120
Trenntransformatoren173

U Seite

uni-cart8
uni-cart Basisgestell100

V Seite

Videoschrankwagen **classic-cart**61
Videowagen **classic-cart**60
Videowagen **compact-cart**76
Videowagen **pro-cart**39

Z Seite

Zubehör94
Zylinderschrauben178

uni-cart

pro-cart

classic-cart

compact-cart

endo-cart

Systemkomponenten
und Zubehör

ITD IST WELTWEIT FÜR SIE DA



Gerne auch persönlich ...

Sie sind herzlich eingeladen, unsere Geräteträger in unserem Ausstellungsraum in Unterhaching live zu erleben. Oder möchten Sie lieber „vor Ort“ beraten werden? Dann kommt unser Medizinprodukteberater gerne zu Ihnen.

In beiden Fällen bitten wir Sie um eine kurze telefonische Terminabsprache.



... oder lieber online ...

Dann klicken Sie bitte unsere Website an. Dort erwarten Sie immer die neuesten Informationen und Produkte. Dazu Downloadmöglichkeiten von Katalogen und Planungshilfen.

www.itd-cart.com

... oder durch unsere nationalen und internationalen Repräsentanten

Unseren Kunden im In- und Ausland stehen unsere Händler und Auslandsvertretungen jederzeit mit Beratung und Service zur Verfügung. Die Adressen finden Sie ebenfalls auf unserer Website.

www.itd-cart.com