



classic-cart



THE UNIVERSAL SOLUTION FOR ALL APPLICATIONS

classic-cart grows to meet different challenges and is used most frequently where a high degree of flexibility and lots of options for equipment are required, e.g. in

- Dermatology
- Endoscopy
- Ultrasound diagnostics
- Ergospirometry, etc.

These are medical settings where **classic-cart** really has an opportunity to put its stability and payload capacity to the test. That's because it forms a generous platform for accommodating a wide range of diagnostic instrumentation, treatment and measuring equipment, plus PCs, monitor arms or infusion stands.





Dermatology application



Neurology application



Endoscopy application



Application of a navigation system for surgery

Technical data

54

Ordering data **classic-cart**

56

THE RIGHT PLATFORM FOR YOUR SOLUTIONS



The **classic-cart basic frame** has a high level of torsional resistance.



The **rear panel** can be removed with two quick fasteners.



The aluminium extrusion with two cable shafts offers storage space for cables and **socket strips**.



A range of **upgrade variants** makes **classic-cart** a variable all-rounder in any hospital and any medical practice.



modul-port jointed arms can be easily mounted on the support extrusion of all equipment carts using the continuous system grid and uniform design, e.g. to accommodate flat screens.

classic-cart impresses in every detail

Perfect functionality

- The basic frame provides safe cabling in optionally supplied power columns and many other upgrade options.
- **classic-cart** is supplied in different heights and widths, and a wide range of variants. This permits **classic-cart** to be configured for virtually any requirement.
- **classic-cart** accommodates a payload of up to 150 kg / 330 lbs.
- Rear panels provide protection against unauthorized access and fast access for service or assembly operations.

Safe power supply

- The optionally supplied central on and off switch is integrated in the right-hand power column as standard.
- Socket strips or power cables and data lines can be accommodated in the spacious power columns.

Smart cable management

- The optional use of power columns permits separation of data lines and power cables.
- Rubber lips guarantee short visible connections to equipment.



THE MODULE SYSTEM FOR INDIVIDUAL SOLUTIONS

The modular structure is the defining feature of the entire ITD product range. It allows all support systems to be configured, upgraded or modified for specialist functions and application areas. This capability allows users to react fast and consistently to any changes or new customer requirements.

The display presented alongside shows a small selection of system components and accessories for the **classic-cart** equipment carts. The entire accessories range with extensive descriptions and ordering information is presented in a user-friendly format from page 94.

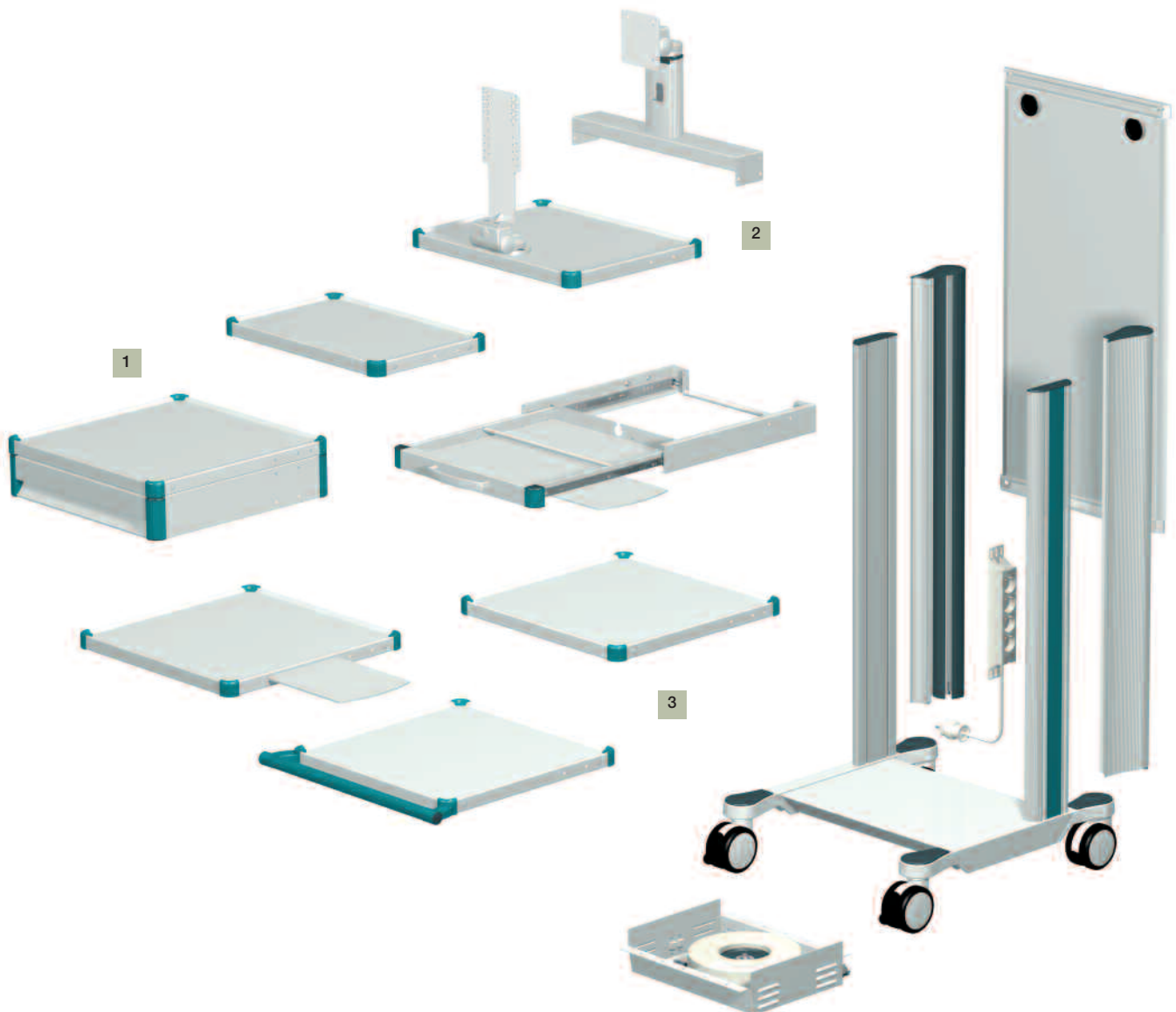



1 The **drawers** are supplied in different versions. A labelling strip on the front trim gives a fast overview.

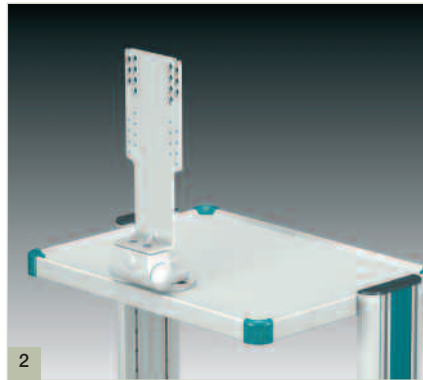

2 The **tilt and swivel monitor holder** with VESA 75 / 100 adaptor can be mounted between the two vertical extrusions.

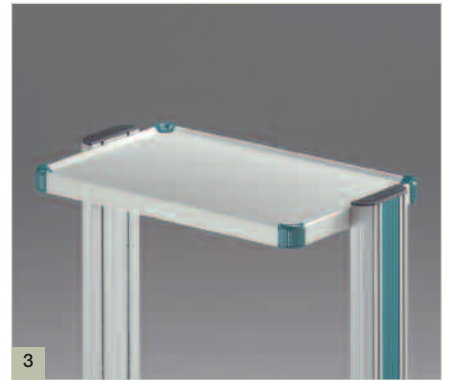

3 The **shelves** are supplied in different versions and widths. They are supplied from a depth of 320 mm.

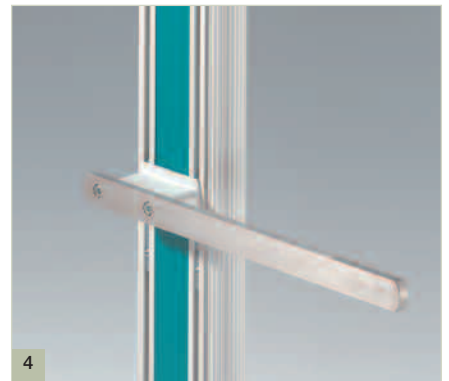

4 A **standard runner** as mounting for e.g. an endoscope holder can be easily mounted on the vertical extrusion.



5 The **endoscope holder** can be mounted variably on the shelves using two rail fasteners.



For an overview of system components and accessories, see page

62

DESIGN ELEMENTS AND DIMENSIONS

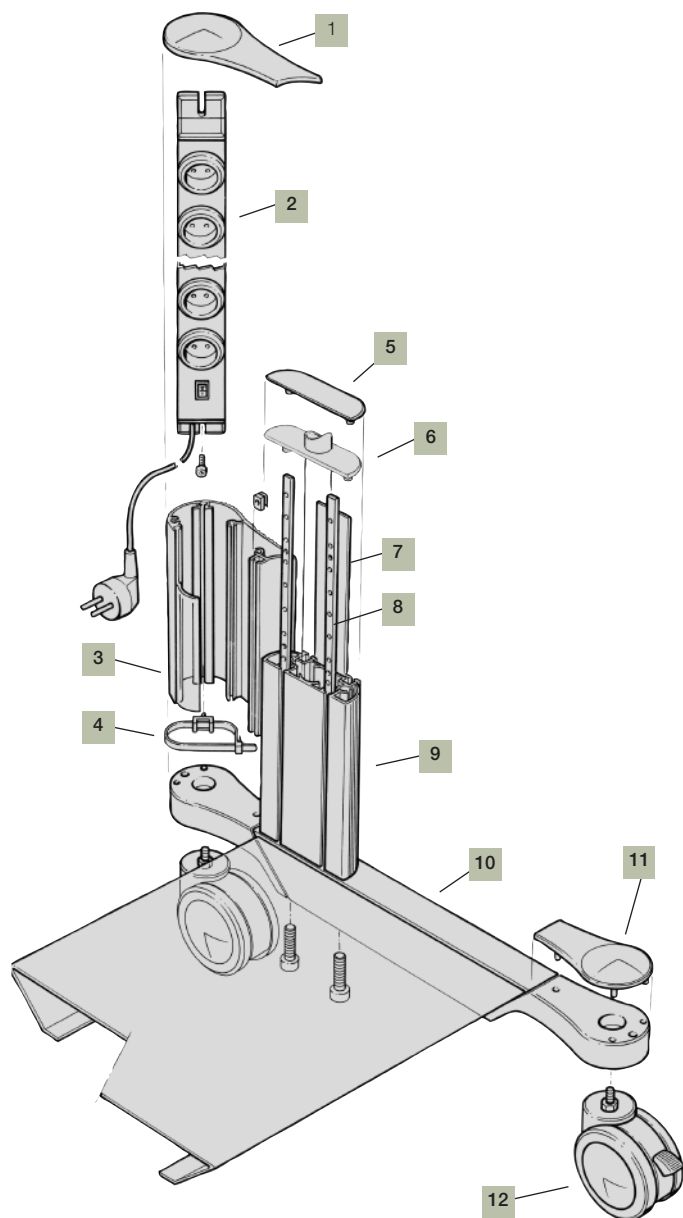

- 1 Cap of the power column made of plastic (ABS)
- 2 Socket strip, for assembly in the power column
- 3 Power column (made of extruded aluminium)
- 4 Cable tie
- 5 Cap of the vertical extrusions made of plastic (ABS)
- 6 Cap of the vertical extrusions made of plastic (ABS) with hole (Ø 25 mm), is used with accessories in the guide
- 7 Decorative trim (made of sheet steel), in RAL 5021 (Water Blue), RAL 5013 (Cobalt Blue) or RAL 7035 (Light Grey), powder-coated
- 8 Tapped strip (made of steel) for mounting all system components in the cart interior (tapped holes M6 in increments of 32 mm)
- 9 Vertical extrusion (made of extruded aluminium), in RAL 7035 Light Grey, powder-coated
- 10 Base (made of steel) zinc-plated with stabilizers (made of cast aluminium) and powder-coated
- 11 Cap of the stabilizer (made of plastic)
- 12 Twin swivel castors with Ø 100 mm or Ø 125 mm, two with wheel locks, optionally also supplied in conductive version

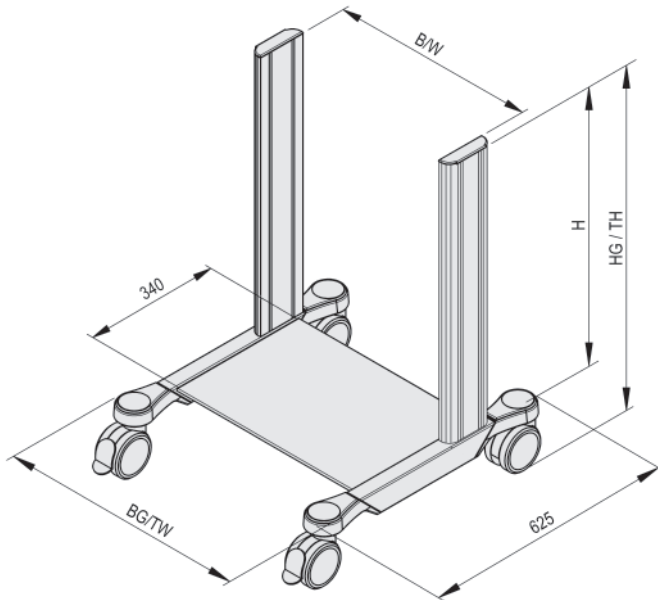

Total width TW	Installation width W
564 mm	450 mm
614 mm	500 mm
714 mm	600 mm

Installation height H	Length of the extrusion H	TH for Castors Ø 100 mm	TH for Castors Ø 125 mm
21 U ¹⁾	675 mm	829 mm	857 mm
30 U ¹⁾	963 mm	1117 mm	1145 mm
40 U ¹⁾	1603 mm	1757 mm	1785 mm

Load capacity

■ Basic frame total payload	150 kg / 330.0 lbs
■ Shelf	50 kg / 110.0 lbs
■ Shelf pullout	20 kg / 44.0 lbs
■ Drawer with lock	20 kg / 44.0 lbs
■ Drawer without lock	3 kg / 6.6 lbs

Setup

- 1 Base
- 2 vertical extrusions each with two tapped strips (32 mm increments)
- 4 twin swivel castors with Ø 100 mm or Ø 125 mm, two with wheel locks.
All sizes are also supplied in a conductive version.
- Comprehensive system of components and accessories for different applications
- Supplied fully assembled

¹⁾ 1 U = 32 mm

ORDER CONFIGURATIONS



classic-cart Equipment cart, 21 U¹⁾

Order number:

Installation width 500 mm GW.5202.XXX²⁾

Installation width 600 mm GW.6202.XXX²⁾

Basic frame **Profi 21 U¹⁾**,
fitted with:

- 4 twin swivel castors Ø 100 mm,
2 with wheel locks
- 1 shelf with handle
- 1 shelf

Load capacity: 150 kg / 330 lbs

Finish:

- RAL 7035 Light Grey powder-coated
- **Trim colour and handles** see optionally ²⁾

classic-cart Equipment cart, 21 U¹⁾

Order number:

Installation width 500 mm GW.5208.XXX²⁾

Installation width 600 mm GW.6208.XXX²⁾

Basic frame **Profi 21 U¹⁾**,
fitted with:

- 4 twin swivel castors Ø 100 mm,
2 with wheel locks
- 1 shelf with handle
- 1 shelf
- 1 drawer

Load capacity: 150 kg / 330 lbs

Finish:

- RAL 7035 Light Grey powder-coated
- **Trim colour and handles** see optionally ²⁾

¹⁾ 1 U = 32 mm

²⁾ **Trim colour:** Make sure you replace .XXX with .901 = RAL 5021 Water Blue, .902 = RAL 5013 Cobalt Blue, .903 = RAL 7035 Light Grey

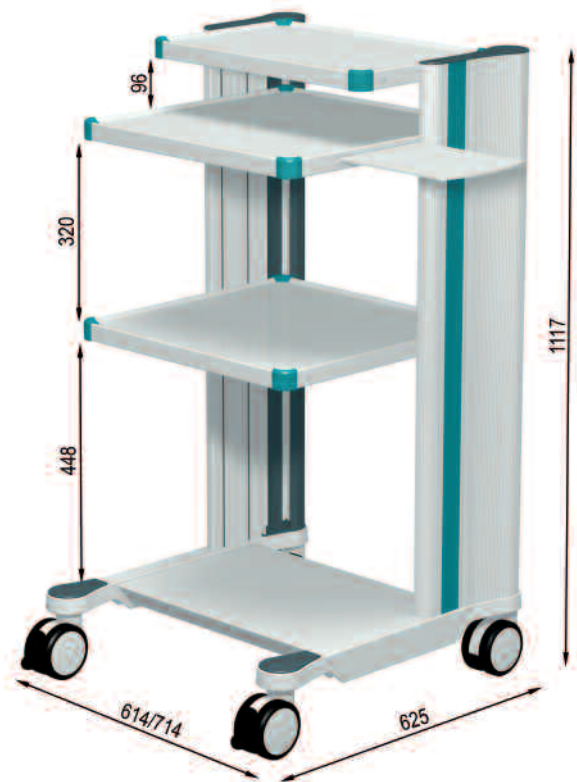
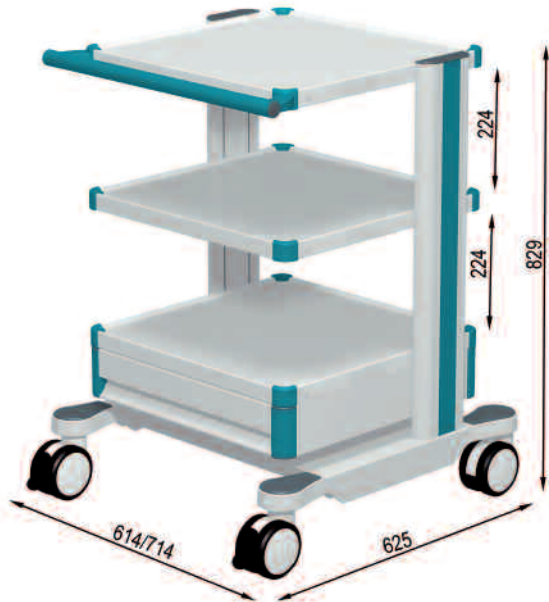

classic-cart Equipment cart, 21 U¹⁾

Order number:

Installation width 500 mm GW.5210.XXX²⁾

Installation width 600 mm GW.6210.XXX²⁾

Basic frame **Profi 21 U¹⁾**,
fitted with:

- 4 twin swivel castors Ø 100 mm,
2 with wheel locks
- 1 shelf with handle
- 2 shelves
- 1 drawer

Please note:

The following applies to articles on page 57:

Load capacity: 150 kg / 330 lbs

Finish:

- RAL 7035 Light Grey powder-coated
- **Trim colour** and **handles** see optionally ²⁾

classic-cart PC Cart, 30 U¹⁾

Order number:

Installation width 500 mm GW.5308.XXX²⁾

Installation width 600 mm GW.6308.XXX²⁾

Basic frame **Profi 21 U¹⁾**,
fitted with:

- 4 twin swivel castors Ø 100 mm,
2 with wheel locks
- 1 shelf depth 320 mm
- 1 fixed shelf with side pullout mousepad
- 1 shelf
- 2 power columns

safety-cart PC Cart, 30 U¹⁾

Order number:

Installation width 500 mm GW.5309.XXX²⁾

Installation width 600 mm GW.6309.XXX²⁾

As above, also fitted with:

- 1 plug removal barrier
- 1 socket strip 8-way with external earth and central on/off switch in the power column

¹⁾ 1 U = 32 mm

²⁾ **Trim colour:** Make sure you replace .XXX with .901 = RAL 5021 Water Blue, .902 = RAL 5013 Cobalt Blue, .903 = RAL 7035 Light Grey

ORDER CONFIGURATIONS



classic-cart Equipment cart, 30 U¹⁾

Order number:

Installation width 500 mm GW.5302.XXX²⁾

Installation width 600 mm GW.6302.XXX²⁾

Basic frame **Profi 40 U¹⁾**,
fitted with:

- 4 twin swivel castors Ø 100 mm,
2 with wheel locks
- 1 shelf with handle
- 3 shelves
- 1 drawer

Load capacity: 150 kg / 330 lbs

Finish:

- RAL 7035 Light Grey powder-coated
- **Trim colour and handles** see optionally ²⁾

classic-cart Equipment cart, 40 U¹⁾

Order number:

Installation width 500 mm GW.5400.XXX²⁾

Installation width 600 mm GW.6400.XXX²⁾

Basic frame **Profi 40 U¹⁾**,
fitted with:

- 4 twin swivel castors ø 100 mm,
2 with wheel locks
- 1 shelf with handle
- 3 shelves

Load capacity: 150 kg / 330 lbs

Finish:

- RAL 7035 Light Grey powder-coated
- **Trim colour and handles** see optionally ²⁾

¹⁾ 1 U = 32 mm

²⁾ **Trim colour:** Make sure you replace .XXX with .901 = RAL 5021 Water Blue, .902 = RAL 5013 Cobalt Blue, .903 = RAL 7035 Light Grey



classic-cart Equipment cart, 40 U¹⁾

Order number:

Installation width 500 mm GW.5404.XXX²⁾

Installation width 600 mm GW.6404.XXX²⁾

Basic frame **Profi 40 U¹⁾**,
fitted with:

- 4 twin swivel castors ø 100 mm,
2 with wheel locks
- 1 shelf with handle
- 3 shelves
- 1 drawer

Load capacity: 150 kg / 330 lbs

Finish:

- RAL 7035 Light Grey powder-coated
- **Trim colour and handles** see optionally ²⁾

classic-cart Equipment cart, 40 U¹⁾

Order number:

Installation width 500 mm GW.5406.XXX²⁾

Installation width 600 mm GW.6406.XXX²⁾

Basic frame **Profi 40 U¹⁾**,
fitted with:

- 4 twin swivel castors ø 100 mm,
2 with wheel locks
- 1 shelf with handle
- 4 shelves
- 1 drawer

Load capacity: 150 kg / 330 lbs

Finish:

- RAL 7035 Light Grey powder-coated
- **Trim colour and handles** see optionally ²⁾

¹⁾ 1 U = 32 mm

²⁾ **Trim colour:** Make sure you replace .XXX with .901 = RAL 5021 Water Blue, .902 = RAL 5013 Cobalt Blue, .903 = RAL 7035 Light Grey

ORDER CONFIGURATIONS

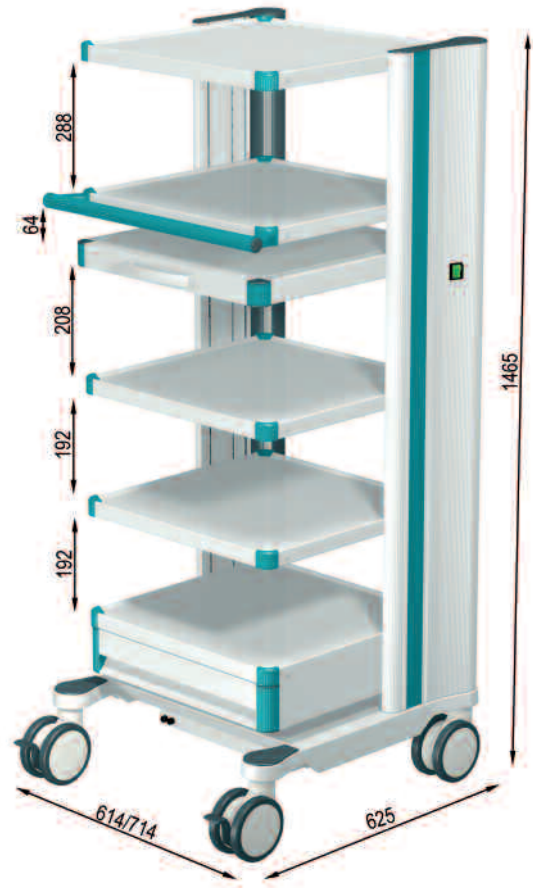
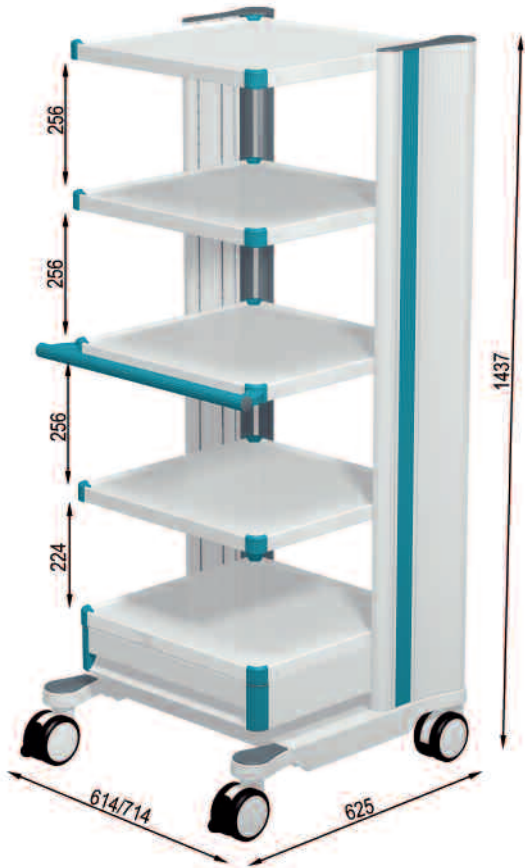

classic-cart Video cart, 40 U¹⁾

Order number:

Installation width 500 mm VW.5402.XXX²⁾

Installation width 600 mm VW.6402.XXX²⁾

Basic frame **Profi 40 U¹⁾**,
fitted with:

- 4 twin swivel castors ø 100 mm, **conductive**
2 with wheel locks
- 1 shelf with handle
- 4 shelves
- 1 drawer
- 2 power columns

Load capacity: 150 kg / 330 lbs

Finish:

- RAL 7035 Light Grey powder-coated
- **Trim colour** and **handles** see optionally ²⁾

classic-cart Video cart, 40 U¹⁾

Order number:

Installation width 500 mm VT.5400.XXX²⁾

Installation width 600 mm VT.6400.XXX²⁾

Basic frame **Profi 40 U¹⁾**,
fitted with:

- 4 twin swivel castors ø 125 mm, **conductive**
2 with wheel locks
- 1 shelf with handle
- 1 shelf pullout
- 4 shelves
- 1 drawer
- 2 power columns
- 1 isolating transformer 1.6 kVA
(technical description in the accessories section
from p. 175)

Load capacity: 150 kg / 330 lbs

Finish:

- RAL 7035 Light Grey powder-coated
- **Trim colour** and **handles** see optionally ²⁾

¹⁾ 1 U = 32 mm

²⁾ **Trim colour:** Make sure you replace .XXX with .901 = RAL 5021 Water Blue, .902 = RAL 5013 Cobalt Blue, .903 = RAL 7035 Light Grey



classic-cart Video rack cart, 40 U¹⁾

Order number:

Installation width 500 mm VS.5402.XXX²⁾

Installation width 600 mm VS.6402.XXX²⁾

Basic frame **Profi 40 U¹⁾**,
fitted with:

- 4 twin swivel castors ø 100 mm, **conductive**
2 with wheel locks
- 1 shelf with handle
- 4 shelves
- 1 drawer
- 2 power columns
- 2 side panels
- 1 rear panel

Load capacity: 150 kg / 330 lbs

Finish:

- RAL 7035 Light Grey powder-coated
- **Trim colour** and **handles** see optionally ²⁾

classic-cart Video rack cart, 30 U¹⁾

Order number:

Installation width 500 mm VS.5302.XXX²⁾

Basic frame **Profi 30 U¹⁾**,
fitted with:

- 4 twin swivel castors ø 100 mm, **conductive**
2 with wheel locks
- 1 shelf with handle
- 1 shelf pullout with handle and mousepad
- 1 drawer
- 1 pedestal rack - 1 shelf base
- 2 glass doors with handle
- 2 power columns
- 2 side panels
- 1 rear panel

Load capacity: 150 kg / 330 lbs

Finish:

- RAL 7035 Light Grey powder-coated
- **Trim colour** and **handles** see optionally ²⁾

¹⁾ 1 U = 32 mm

²⁾ **Trim colour:** Make sure you replace .XXX with .901 = RAL 5021 Water Blue, .902 = RAL 5013 Cobalt Blue, .903 = RAL 7035 Light Grey

OVERVIEW

SYSTEM COMPONENTS AND ACCESSORIES

Basic frames Profi		<i>for installation width</i>	<i>W 500</i>	<i>W 600</i>
		Height 21 U	GW.5502.XXX	GW.6502.XXX ¹⁾
		30 U	GW.5503.XXX	GW.6503.XXX ¹⁾
		40 U	GW.5504.XXX	GW.6504.XXX ¹⁾
Power columns		Height 21 U	GW.0242.991	
		30 U	GW.0243.991	
		40 U	GW.0244.991	
	prepared for on and off switch	Height 21 U	GW.0660.991	
		30 U	GW.0661.991	
		40 U	GW.0662.991	
Rear panel		<i>for installation width</i>	<i>W 500</i>	<i>W 600</i>
		Height 21 U	GW.5150.991	GW.6150.991
		30 U	GW.5151.991	GW.6151.991
		40 U	GW.5152.991	GW.6152.991
Castor conversion kits	Ø 100 mm, conductive, instead of standard Ø 100 mm		ZV.9922.999	
	Ø 125 mm, conductive, instead of standard Ø 100 mm		ZV.9923.999	
	Ø 125 mm, conductive, instead of standard Ø 100 mm, conductive		ZV.9924.999	
Shelf		<i>for installation width</i>	<i>W 500</i>	<i>W 600</i>
		without handle	GW.5001.XXX	GW.6001.XXX ¹⁾
		with handle	GW.5002.XXX	GW.6002.XXX ¹⁾
		with mousepad	GW.5035.XXX	GW.6035.XXX ¹⁾
		with mousepad and handle	GW.5049.XXX	GW.6049.XXX ¹⁾
		depth 320 mm	GW.5025.XXX	GW.6025.XXX ¹⁾
		depth 320 mm for retrofitting with monitor holder	GW.5027.XXX	GW.6027.XXX ¹⁾
		pullout	GW.5040.XXX	GW.6040.XXX ¹⁾
Printer shelf	installation depth 490 mm		GW.5008.XXX	GW.6008.XXX ¹⁾
Rack base	installation depth 490 mm		GW.5075.991	GW.6075.991
Keyboard drawer	without mousepad		GW.5034.XXX	GW.6034.XXX ¹⁾
	with mousepad		GW.5036.XXX	GW.6036.XXX ¹⁾
Side shelf		<i>Width</i>	<i>200 mm</i>	<i>300 mm</i>
		right, depth 400 mm	GW.0238.XXX	GW.0248.XXX ¹⁾
		left, depth 400 mm	GW.0239.XXX	GW.0249.XXX ¹⁾
Computer holder			TS.6144.991	
Monitor holder		<i>for installation width</i>	<i>W 500</i>	<i>W 600</i>
		crosspiece with monitor holder for 17.6 lbs	GW.5024.991	GW.6024.991
		crosspiece with monitor holder for 30.8 lbs	GW.5096.991	GW.6096.991
		monitor shelf with monitor holder up to 30.8 lbs	GW.5091.XXX	GW.6091.XXX ¹⁾

¹⁾ **Trim colour:** Make sure you replace **.XXX** with **.901** = RAL 5021 Water Blue, **.902** = RAL 5013 Cobalt Blue, **.903** = RAL 7035 Light Grey

Monitor holder	on the side of the vertical extrusion	GW.0708.991		
Drawer unit		<i>for installation width</i>		
	1 unit 3 U high	W 500	W 600	
	1 unit, 6 U high	GW.5051.XXX	GW.6051.XXX	1)
Baskets		ZV.9967.800		
Gallery		<i>for installation width</i>		
	for shelf / drawer	W 500	W 600	
Endoscope holder		<i>single</i>	<i>double</i>	
	of the vertical extrusion	GW.0393.800	GW.0472.800	
	for assembly an 2 shelves	GW.0394.991	GW.0473.991	
Connector holder		ZV.9833.999		
Hose holder		GW.9882.999		
Camera holder	assembly at the side on the shelf	GW.9990.999		
	with clamp	GW.9983.991		
	with mounting	GW.9808.991		
Cable holder		GW.9807.991		
Gel bottle holder		GW.0800.991		
Bottle holder	for Ø 120 mm, 1 l	GW.0400.991		
	for Ø 145 mm, 2 l	GW.0401.991		
	for rinsing bottle	GW.9805.999		
Gas bottle holder	for gas bottles with max. 2 l content	GW.0466.991		
	for gas bottles with Ø 145 mm, 3 l / 5 l / 10 l content	GW.0160.991		
	for gas bottles with Ø 205 mm, 20 l / 50 l	GW.0285.991		
Infusion stand	4-arm with one hand - adjustment, 4 x 2 kg / 4.4 lbs	ZV.9882.800		
	4-arm with one hand - adjustment, 4 x 5 kg / 11 lbs	ZV.9464.800		
Standard runner		GW.9801.991		
Anchor		ZV.9820.799		
Holder for suction system		<i>Strässle/Ergoline</i>	<i>Hellige/KISS</i>	<i>Ohlenschläger</i>
	assembly in the outside T-slots	GW.0570.991	GW.0702.991	GW.0704.991
	assembly in the power column	GW.0717.991		
Foot switch shelf / cradle	under the crosspiece of the basic frame	ZV.9980.991		
	mounted on the sides of the vertical extrusion	ZV.9991.991		
Holder for transducer		GW.0843.991		
Box holder		ZV.9832.999		
Pivot arm	single, with VESA 75/100 adaptation for flat screen	TS.6063.991		
	double, with VESA 75/100 adaptation for flat screen	TS.6064.991		

1) **Trim colour:** Make sure you replace .XXX with .901 = RAL 5021 Water Blue, .902 = RAL 5013 Cobalt Blue, .903 = RAL 7035 Light Grey

OVERVIEW

SYSTEM COMPONENTS AND ACCESSORIES

Variable height arm	Length 400 mm	L 400 mm	ZV.9538.999	
	single	Load capacity 8 kg / 17.6 lbs	L 750 mm	ZV.9741.999
		Load capacity 10 - 13 kg / 22 - 28.6 lbs	L 750 mm	ZV.9724.999
	double	Load capacity 8 kg / 17.6 lbs	L 1190 mm	ZV.9740.999
		Load capacity 10 - 13 kg / 22 - 28.6 lbs	L 1190 mm	ZV.9721.999
Jointed arm	with hose clamps, for cable management		ZV.9955.799	
Socket strips	6-way EURO		ZV.9501.999	
	3-way earthed with switch		ZV.9977.999	
	6-way earthed		ZV.9503.999	
	8-way earthed		ZV.9504.999	
	8-way earthed with switch		ZV.9502.999	
	8-way earthed with central on / off switch		ZV.9505.999	
	6-way, French Standard		ZV.9506.999	
Socket strip mounting kit			GW.0631.991	
Plug removal barrier			GW.0633.991	
Cable winder			FC.0253.991	
Isolating transformer		without insulation monitor	with insulation monitor	
	660 VA with 4-way socket strip EURO	ZV.9404.999	ZV.9405.999	
	1000 VA with 8-fach socket strip EURO	ZV.9402.999	ZV.9403.999	
	1600 VA with 8-fach socket strip EURO	ZV.9400.999	ZV.9401.999	

1) **Trim colour:** Make sure you replace **.XXX** with **.901** = RAL 5021 Water Blue, **.902** = RAL 5013 Cobalt Blue, **.903** = RAL 7035 Light Grey

You will find a comprehensive description and ordering information on all components suitable for **classic-cart** in the **system components and accessories** section.

System components and accessories from page

94

Order number index from page

180

